



VACUUM PACKING MACHINE SU-520GP+ CC 120/60/1

Tabletop model. 700 cf/h. 17+17 “.



P/N. 1141127



SALES DESCRIPTION

Two sealing bars (17+17 “).
700 cf/h Busch vacuum pump.
Vacuum controlled by sensor.

- ✓ Powered by Busch.
- ✓ Vacuum controlled by sensor.
- ✓ Vacuum PLUS.
- ✓ LCD colour screen: all information at a glance.
- ✓ Backlit touch keyboard.
- ✓ Programmable: 25-programme memory. Blocking option.
- ✓ “Pause” button.
- ✓ Phased vacuum programme.
- ✓ Detection of the evaporation of liquids.
- ✓ Double seal.
- ✓ Cordless sealing bar.
- ✓ Progressive decompression.
- ✓ Vac-Norm ready with Automatic decompression.
- ✓ Stainless steel body and chamber. Long-shaped, deep-drawn chamber.
- ✓ Damped transparent lid of high durability polycarbonate.
- ✓ Dry-oil programme for drying the pump.
- ✓ Working hours counter for oil changes.
- ✓ Safety system with protection against vacuum failure.

INCLUDES

- ✓ Filling plate
- ✓ Inert gas flush (2+2 injectors).
- ✓ Bluetooth connectivity
- ✓ Printer connection
- ✓ “Plus” sealing system

OPTIONS

- Printer
- Vacuum packing pouches
- Vac-Norm external vacuum kit, containers and accessories
- Bag cutting kit
- Support for liquids
- Additional filling plates

ACCESSORIES

- Bag cutting kits
- Filling plates
- Liquid insert plates
- Vac-norm external vacuum kits
- Vac-norm containers
- Smooth bags for vacuum packing
- Trolley for vacuum packing machines
- Thermal labels for CG2 / RB printer
- RB Desktop printer for SU vacuum packing machines
- Thermal transfer labels for RB printer

SPECIFICATIONS

Pump capacity: 700 cf/h
 Bar length: 17+17 “
 Total loading: 1.25 Hp
 Vacuum pressure (maximum): 2 mbar
 Electrical supply: 120 V / 50-60 Hz / 1 ~ (13 A)
 Plug: USA (NEMA 5-15P / 2P+G)

Internal dimensions

- ✓ Width: 22.3 “
- ✓ Depth: 16.9 “
- ✓ Height: 8.4 “

External dimensions (WxDxH)

- ✓ Depth: 21.7 “
- ✓ Height: [v:dim_ext_alto_us_2] (120V) / 20.1 “ (230V)
- ✓ Width: 24.9 “
- ✓ Depth: 21.7 “
- ✓ Height: 20.1 “

Net weight: 167.55 lbs
 Noise level (1m.): 75 dB(A)
 Background noise: 32 dB(A)

Crated dimensions

30.9 x 24.1 x 27.0 “
 Gross weight: 186.5 lbs.

FOOD PRESERVATION AND SOUS-VIDE
VACUUM PACKING MACHINES - “SENSOR ULTRA” LINE





VACUUM PACKING MACHINE SU-520GP+ CC 120/60/1

Tabletop model. 700 cf/h. 17+17 “.



P/N. 1141127

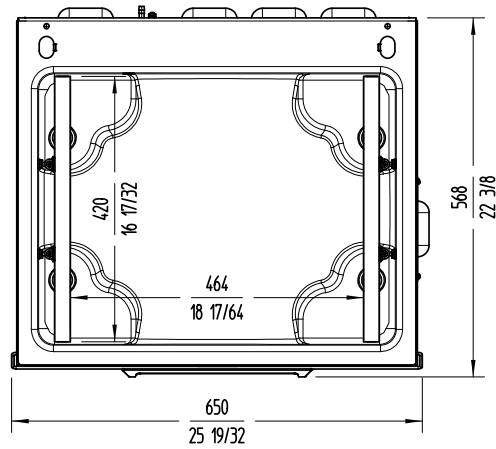
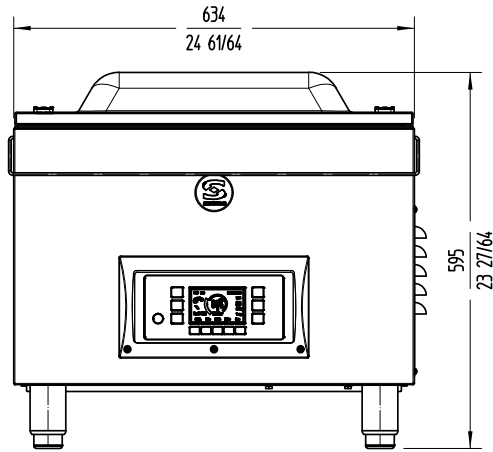
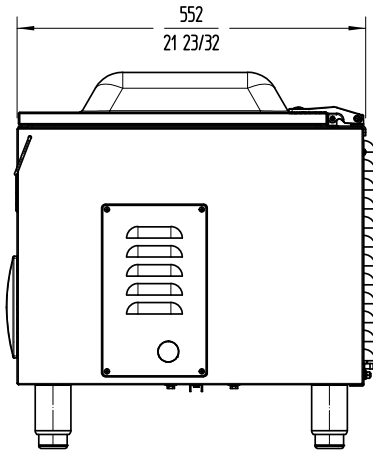

FOOD PRESERVATION AND SOUS-VIDE
VACUUM PACKING MACHINES - "SENSOR ULTRA" LINE

sammic | www.sammic.us
Food Service Equipment Manufacturer

usa@sammic.com
1225 Hartrey Avenue
60202-1056 Evanston, IL

phone +1 (224) 307-2232
toll free +1 844 275 3848



Project	Date
Item	Qty
Approved	

product sheet
updated 09/28/22