

# GLASS DOOR MERCHANDISER FREEZER SWING DOORS



## EMGF48

## EM Series



### Refrigeration System

- Bottom mounted, self-contained and fully detachable Blizzard R290 condensing unit uses environmentally friendly, EPA-compliant R290 refrigerant with zero (0) Ozone Depletion Potential (ODP) and three (3) Global Warming Potential (GWP). Blizzard R290 is easily replaceable and requires no on-site brazing.
- Electronically commutated (ECM) fan motors achieve rapid cooling with less energy consumption.
- Full-length air duct ensures optimal cold air distribution (except EMGR5(B)).
- Air circulation guard keeps floor vents from obstruction (except EMGR5(B)).
- Time-initiated and temperature-terminated auto defrost cycle for seamless operation.
- Large capacity, corrosion-resistant condenser and evaporator coils.
- Self-maintaining, energy-efficient condensate drain pan requires no external drains or electric heaters.
- High performance, auto-reverse condenser fan motor supports compressor ventilation and condenser coil cleaning.
- Pre-wired and ready to plug, 115V/60Hz/1Ph, NEMA 5-15P.

### Cabinet Construction

- White coated steel exterior. White coated interior.
- Open spaced interior with no walls between compartments.
- Stainless steel floor interior has rounded corners and detachable drain plug for ease of cleaning.
- 2.5" thick high density polyurethane insulation.
- Four 5" swivel casters with locks on front set. Leg stabilizers standard.

### Lighting

- Shielded LED bar lighting with on/off switch provides bright, high color illumination at lower heat output.

### Doors

- Low emissivity double glass panes reflect UV rays for efficient cooling.
- Matte finish aluminum door frames.
- Frame heaters prevent exterior moisture build up.
- Defroster strips keep glass planes clear and fog-free.
- Self-closing with adjustable torsion system for a positive seal.
- Snap-in magnetic door gasket make cleaning and replacement an easy process.
- High strength, die-cast door handles.
- Pre-installed door locks keep your items safe from theft.

### Shelving

- Four epoxy coated, steel wire shelves with airflow guard per section.
- Height adjustable stainless steel clips.

### Temperature Control

- Multi-function digital controller with easy to read LED display.
- Factory preset temperature, -4°F. Temperature setting range from -10°F to 54°F.

### Options

- Additional shelving.
- 3" swivel casters with locks.
- 3.5" – 6" height-adjustable and interchangeable legs.



Type	Doors	Capacity Cu. Ft.	Shelves	Refrigerant	HP	Power V-Hz-Ph	Amps	Crated Weight	Exterior Dimensions		
									L	D	H*
FRZ	2	48	8	R-290	1 x 2	115-60-1	13	771 lbs	54.75"	31.625"	80.125"

(†)Based on evaporating temperature of 23°F (-5°C) & condensing temperature of 131°F (55°C). (‡) Product capacity is calculated based on standard industry figures. (※) Reference plan view for clarification on caster/unit height. If dimensions and capacity are critical, please contact Everest Refrigeration. Blizzard R290 replacement is at the sole discretion of Everest Refrigeration. Specifications subject to change without notice.

# GLASS DOOR MERCHANDISER FREEZER SWING DOORS



## EMGF48

## EM Series

### DIMENSIONAL DATA

External Dims.	L	54.75 in.
	D	31.625 in.
	H*	80.125 in.
Crated Weight		771 lbs.
Doors/Drawers/Lids		2
Max Weight Support		-

### STORAGE DATA

Net Capacity Cu. Ft. <b>†</b>	48
Shelves	8
Barrels	-
20 oz. Bottles	-
12 oz. Bottles	-
12 oz. Cans	-
8" Mugs	-
# of Pans (Top)	-
# of Pans (Drawer)	-
Dividers	-
Trays	-

### ELECTRICAL DATA

Voltage	115-60-1
Full Load Amperage	13A
Feed Wires w/ Ground	3
Cord Length	9ft
NEMA Plug Type	NEMA 5-20P

### REFRIGERATION DATA

Compressor	Bottom
Refrigerant	R-290
Compressor HP	1 x 2
BTU/HR <sup>†</sup>	4036 x 2

### KEY

<b>D</b>	Door	<b>R</b>	Refrigerator
<b>L</b>	Lid	<b>REF</b>	Refrigerator
<b>H</b>	Half Door	<b>F</b>	Freezer
<b>FD</b>	Full Door	<b>FRZ</b>	Freezer
<b>SD</b>	Solid Door	<b>DUAL</b>	REF/FRZ Combo
<b>GD</b>	Glass Door	<b>DR</b>	Drawer

	Elevation	Right	Plan	3D	Back

### PLAN VIEW

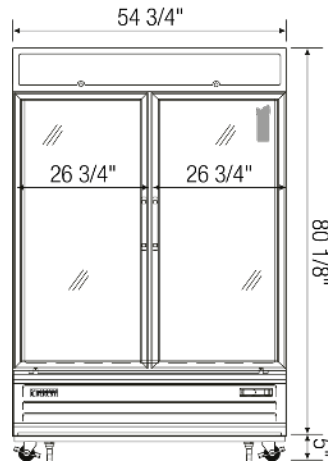

FRONT

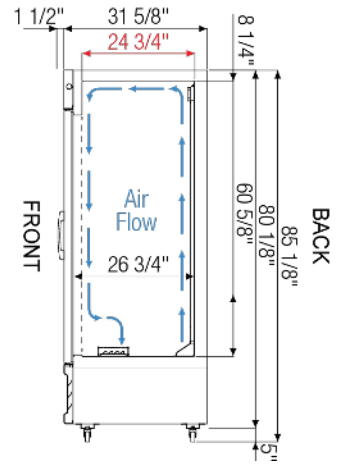

SIDE

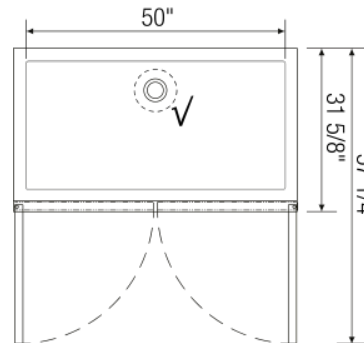

TOP

### ACCESSORIES & OPTIONS

- Additional Shelving - Contact Everest Refrigeration for more information.
- AJL03-00 - Interchangeable Leg for Caster (Optional)
- CASA3-01 - 3" Overall Height Caster Assembly - (2) Front (2) Rear

(†)Based on evaporating temperature of 23°F (-5°C) & condensing temperature of 131°F (55°C). (‡) Product capacity is calculated based on standard industry figures. (\*) Reference plan view for clarification on caster/unit height. If dimensions and capacity are critical, please contact Everest Refrigeration. Blizzard R290 replacement is at the sole discretion of Everest Refrigeration. Specifications subject to change without notice.