

Project:	Quantity:
Model #:	Approval:

For Commercial Use Only

FSS-89 89" Floor Model Reversible Dough Sheeter with Roller Pin, All Stainless Steel Body - 120V



FEATURES

- Full stainless steel construction
- Heavy-duty usage
- Fixed conveyor speed
- Manual roller adjustments
- Preset roller thickness control
- Foldable tables for space saving storage
- Retractable end tables
- Safety features
- Floor model

Streamline dough preparation tasks in your commercial kitchen with the Prepline dough sheeter machine. This sheeter is ideal for bakeries, restaurants, pizzerias, and hotels because it quickly churns out inch after inch of dough for pasta, wraps, pizza and baked goods. This is a 3/4 HP reversible floor model dough sheeter. It comes with stainless steel rollers that are adjustable to support dough thickness between the 1mm and 40mm range. Get more value with the Prepline food service dough sheeter that is built for durability and reliability.

• CE Certified



USR Brands is a US supplier of premium quality commercial cooking, refrigeration and food preparation equipment. Our aim is simple. Produce industry-leading commercial restaurant equipment at reasonable prices, and back it all up with an easy to understand, no nonsense warranty that people can count on.

For Commercial Use Only

TECHNICAL DATA

DIMENSIONS

Working Dimensions	89.6"W x 34.6"D x 42.13"H
Folded Dimensions	29.5"W x 34.6"D x 63"H
Packaging Dimensions	38.2"W x 28.3"D x 67.7"H
Unit Weight	432 lb.
Shipping Weight	556 lb.

ELECTRICAL

Voltage	120
Hertz	60
Phase	1
Kilowatt	0.56
Amps	7.5
Horsepower	3/4
Plug Type	NEMA 5-15P
Power Cord Length	72"

SHEETING

Roller Size	3.5"Dia. x 20.5"W
Roller Adjustable Gap	1-40mm
Conveyor Width	22.5"
Conveyor Belt Length	85"
Conveyor Belt Width	19.7"
Conveyor Belt Speed	18m/min - 32m/min
Roller Speed	124r/min
Max. Dough Capacity	11 lb.

CONSTRUCTION

Exterior Material	Full Stainless Steel
Style	Floor Model
Type	Reversible Dough Sheeter
Foldable Table	Yes
Safety Features	Safety Guards Emergency Stop Button Thermal Overload Device
Mobility	(2) with brakes, (2) without

DIAGRAM

MODEL: FSS-89

MFR ITEM #:

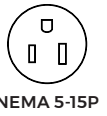

FRONT VIEW

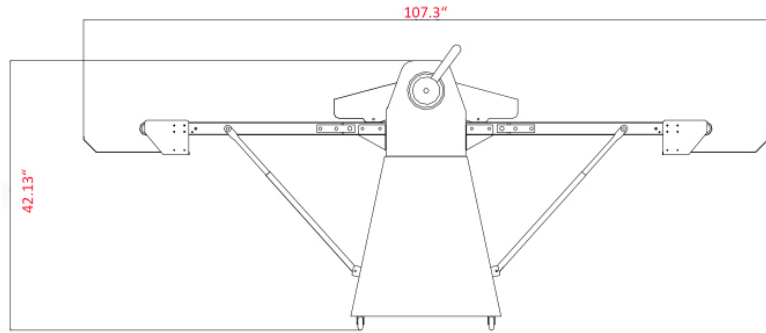

SIDE VIEW

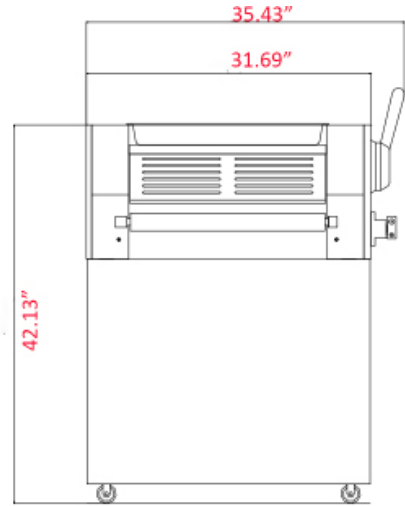

TOP VIEW

