

Project:	Quantity:
Model #:	Approval:

*For Commercial Use Only*

## CSP-81 81" Countertop Reversible Dough Sheeter with Roller Pin - 120V



### FEATURES

- Stainless steel construction
- Heavy-duty usage
- Fixed conveyor speed
- Manual roller adjustments
- Preset roller thickness control
- Foldable tables for space saving storage
- Retractable end tables
- Safety features
- Countertop model

The Prepline dough sheeter machine is a perfect way to streamline food prep operations in your bakery, restaurant, or hotel. Our commercial dough roller allows your staff to rapidly sheet up to 20 inches of dough for pizza, pasta, wraps, and baked goods. This is a classic 3/4 HP reversible countertop model dough sheeter. The stainless steel roller is position-adjustable to support dough thickness between 1mm and 40mm. Save time on dough sheeting and get more value for money with the Prepline dough sheeter.

• CE Certified



**U**SR Brands is a US supplier of premium quality commercial cooking, refrigeration and food preparation equipment. Our aim is simple. Produce industry-leading commercial restaurant equipment at reasonable prices, and back it all up with an easy to understand, no nonsense warranty that people can count on.

Project:	Quantity:
Model #:	Approval:

For Commercial Use Only

## TECHNICAL DATA

### DIMENSIONS

Working Dimensions	81.1"W x 34.6"D x 23.8"H
Folded Dimensions	29.5"W x 34.6"D x 33.1"H
Packaging Dimensions	38.2"W x 28.3"D x 39.4"H
Unit Weight	282 lb.
Shipping Weight	370 lb.

### ELECTRICAL

Voltage	120
Hertz	60
Phase	1
Kilowatt	0.56
Amps	7.5
Horsepower	3/4
Plug Type	NEMA 5-15P
Power Cord Length	72"

### SHEETING

Roller Size	3.5"Dia. x 20.5"W
Roller Adjustable Gap	1-40mm
Conveyor Width	22.5"
Conveyor Belt Length	78.7"
Conveyor Belt Width	19.7"
Conveyor Belt Speed	18m/min - 32m/min
Roller Speed	124r/min
Max. Dough Capacity	11 lb.

### CONSTRUCTION

Exterior Material	Stainless Steel
Style	Countertop Model
Type	Reversible Dough Sheeter
Foldable Table	Yes
Safety Features	Safety Guards Emergency Stop Button Thermal Overload Device

## DIAGRAM

MODEL: CSP-81

MFR ITEM #:



FRONT VIEW

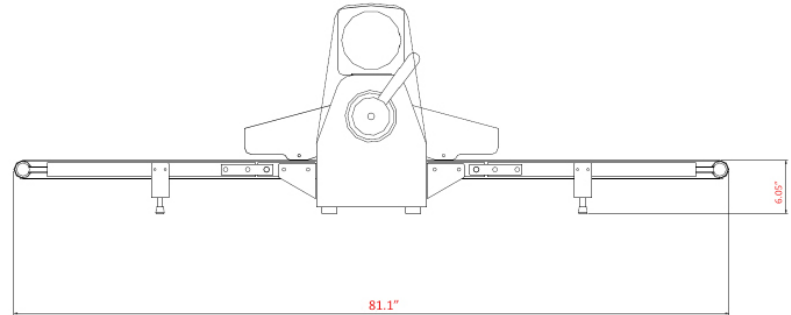

SIDE VIEW

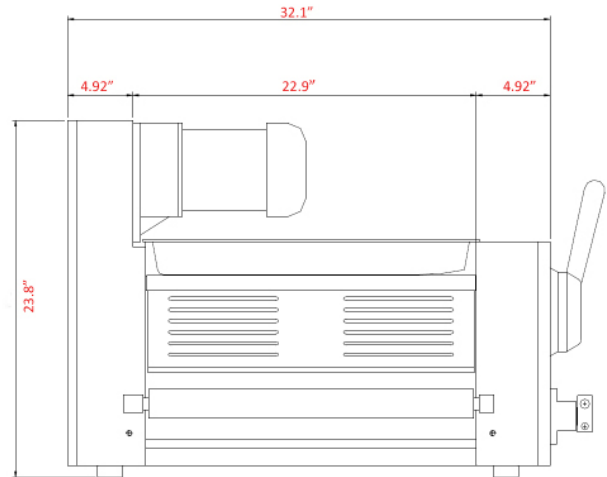

TOP VIEW

