

Project _____

Item Number _____

Quantity _____

Hand Mixer



Hand Mixer - Vortex

Models:

- > Vortex430
- > Vortex550
- > Vortex750

Hand Mixer - Vortex

Features:

- Interchangeable shafts
- Shafts available in 2 lengths: 14" or 18"
- Several sizes available
- Prepares mixtures, soups and sauces
- Liquefies soups, purees fruits and vegetables directly in the cooking pot
- Lightweight and designed to reduce muscle strain and fatigue
- Highly effective cooling system
- Sturdy and light weight fiberglass ABS body
- Fixed and variable speed controls available
- Safety device preventing switching on by mistake
- Powered by 3 different motors
- IPX3 protection
- Quick coupling device
- Cutlery steel knives
- Completely stainless steel shaft and bell

Optional Features:

- 14" or 18" shafts
- storage case
- wall attachment
- whisk
 - whisk with metal gearing
 - demountable and dishwashing safe whisk
- pot support

Univex Corporation

Warranty:

- One year carry in warranty
- Attachments and shafts are 90 days carry in parts/labor.

Cord Length: 9 Feet Long





WE RAISE THE BAR. WE SET THE STANDARD.

Hand Mixer

VORTEX

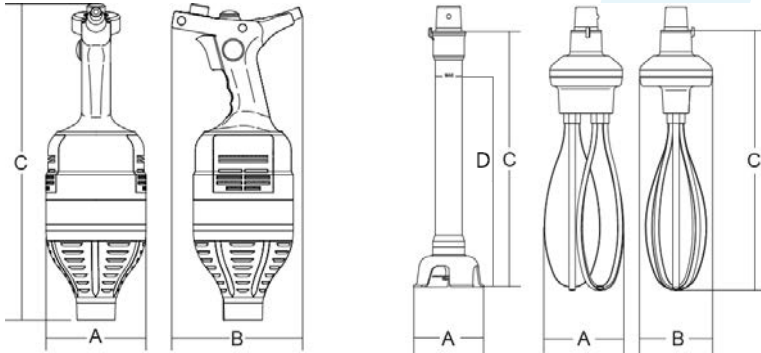

Hand Mixer Dimensions:

Vortex 430 Body:

- A 4.92"
- B 6.45"
- C 15.5"

Shafts:

- A 3.93"
- C 16.3" / 20.3"
- D 14.0" / 18.0"

*Optional Whisk Attachment and Wall hanger

Working Capacity:

- 430: up to 115 Qts
- 550: up to 160 Qts
- 750: up to 210 Qts

Whisk:

- A 4.61"
- B 4.45"
- C 15.16"

18" Shaft Shipping Box Dimensions:
23.23" x 9.06" x 5.91"

Whisk Shipping Box Dimensions:
20.47" x 8.27" x 9.84"

Electrical Information (60Hz)

NEMA #: 5-15-P

	Voltage Type	Voltage	Phase	hp(kW)	Watts	Hertz
Vortex430	Standard	120	1	.6	430	60
Vortex550	Standard	120	1	.8	550	60
Vortex750	Standard	120	1	1	750	60

Shipping Information

Net Weight	Shipping Weight	Overall Dimensions	Freight Class
5.5 lbs (2.5 kg)	6.6 lbs (2.9 kg)	5.9" (15 cm) H x 13" (33 cm) W x 17.3" (44 cm) D	85
7.7 lbs (3.5kg)	8.8 lbs (3.9 kg)	5.9" (15 cm) H x 13" (33 cm) W x 17.3" (44 cm) D	85
8.8 lbs (3.9 kg)	9.9 lbs (4.5 kg)	5.9" (15 cm) H x 13" (33 cm) W x 17.3" (44 cm) D	85



Univex Corporation
www.Univexcorp.com

3 Old Rockingham Rd
Salem, NH 03079
United States of America

TEL: 800.258.6358
INTL TEL: 603.893.6191
FAX: 800.356.5614
INTL FAX: 603.893.1249