



1048

Single and Double Gas Pizza Deck Oven



1048 - SINGLE/DOUBLE

Project _____

Item No. _____

Quantity _____

Ovens consist of basic sections and are a complete and separate unit capable of operating alone or in combination. All data is shown per oven section, unless otherwise indicated. All data is shown per oven section, unless otherwise indicated.

Refer to operator manual specification chart for listed model names.

EXTERIOR CONSTRUCTION

- Full angle iron frame
- Stainless steel front, top, sides and back
- Spring assist door with concealed hinges
- Heavy chrome plated tubular steel door handle
- 32" (794mm) stainless steel legs (for single unit)
- 12" (273mm) stainless steel legs (for double unit)
- Burner door opens easily for ignition, cleaning or adjustment, without removal of any fastenings
- Vitreous fiber insulation at top, back, sides, bottom and doors

INTERIOR CONSTRUCTION

- 47-1/4" x 36" x 10" (1200mm x 914mm x 254mm) oven compartment interior
- Aluminized steel baking compartment liner
- Aluminized steel combustion chamber
- QHT Rokite deck supported by an angle iron frame

OPERATION

- Two free-floating, easily removable duplex-tube burners
- Removable fixed orifices on main and pilot burners
- Main gas valve, temperature control valve and safety pilot valve fully within section body and are accessible through a covered and ventilated compartment in front
- Air mixers with adjustable air shutters and locking device
- Snap throttle thermostat with temperature control range of 300°F (149°C) to 650°F (343°C)

STANDARD FEATURES

- Fahrenheit dial 300°F to 650°F
- QHT (Quick Heat Technology) Rokite deck
- Two year parts and one year labor warranty
- Five year limited oven door warranty*

* For all international markets, contact your local distributor.

NOTE: The company reserves the right to make substitutions of components without prior notice

OPTIONS AND ACCESSORIES

(AT ADDITIONAL CHARGE)

- Flexible gas hose with quick disconnect and restraining device
 - 36" (914 mm)
 - 48" (1219mm)
- Stainless steel stacking crown angle leg frame assembly
- Meteorite deck
- Black legs with casters
- Stainless steel crown angle trim
- Flue connector
- Vent kit

OPTIONS AND ACCESSORIES

(AT NO ADDITIONAL CHARGE)

- Centigrade dial, 150°C to 340°C
- No. 12 gauge (3.02mm) press-formed, reinforced and flanged aluminized steel deck (1048-S)



www.blodgett.com

42 Allen Martin Drive, Essex Junction, VT 05452
Phone: (802) 658-6600 | Fax: (802) 864-0183



1048 PIZZA DECK OVEN

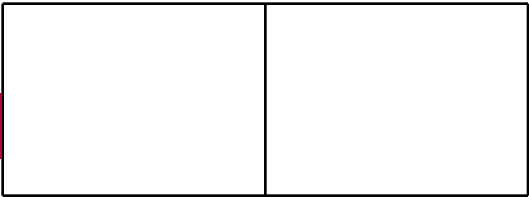

APPROVAL/STAMP

DIMENSIONS ARE IN INCHES (MM)

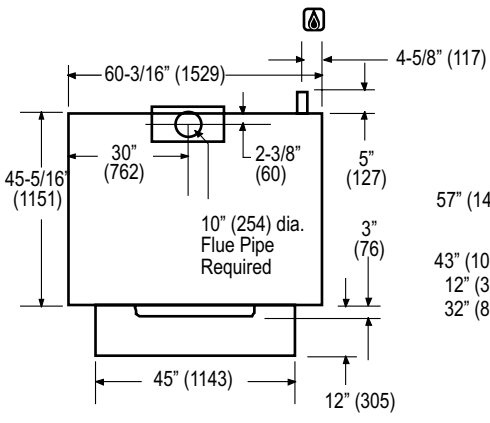

TOP VIEW

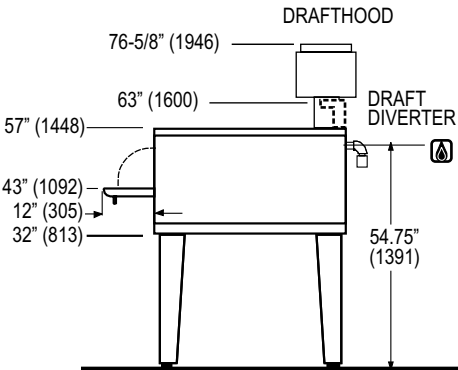

1048 SINGLE

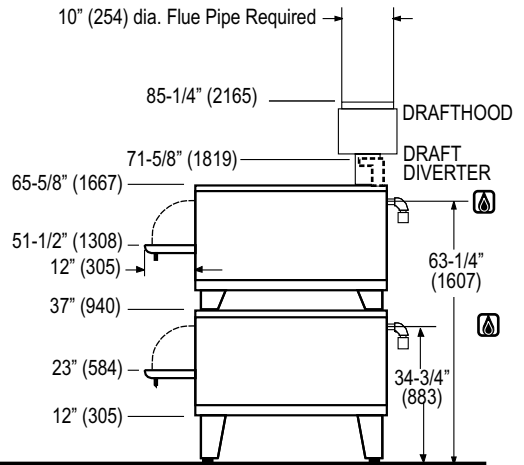

1048 DOUBLE

SHORT FORM SPECIFICATIONS Provide Blodgett (single/double) deck oven, model 1048. Construction shall be stainless steel on front, top, back and sides, and shall be fully insulated on all sides. Oven shall be supported by formed adjustable legs. Door(s) shall be spring assisted with concealed hinges and chrome plated tubular steel handles. Separate burner door provided for ignition, cleaning and adjustment. Each baking compartment shall be 47-1/4" W x 10" H x 36" D and shall be lined with aluminized steel. Deck shall be QHT rokitite. Unit shall be gas heated by two (2) free-floating, easily removable, duplex-type burners controlled by a snap throttle thermostat with range of 300°F to 650°F. Each compartment provided with flue vent. Provide with two year parts and one year labor warranty. Provide with options and accessories as indicated.

DIMENSIONS

Floor space 60-3/16" (1528mm) W x 46-1/2" (1181mm) D
Cooking Compartment (per section)
 Size 47-1/4" (1200mm) W x 10" (254mm) H x 36" (914mm) D
 Area 12.16 sq. ft. (1.1m2) 12.16 sq. ft. (1.1m2)

SECTION DETAILS

	Single	Double
Number of section	1	2
Number of controls	1	2
Number of compartments	1	2

PRODUCT CLEARANCE

From combustible and non-combustible construction
 6" (152 mm)

GAS SUPPLY (per section)

3/4" NPT
Inlet Pressure
 Natural Gas 7.0" W.C. min. - 10.5" W.C. max.
 Propane 11.0" W.C. min. - 13.0" W.C. max.
Manifold Pressure
 Natural Gas 3.5" W.C.
 Propane 10" W.C.

MAXIMUM INPUT

1048B 85,000 BTU/hr per oven section
CE oven Hs - 35 kW Hi - 31.5 kW

MINIMUM ENTRY CLEARANCE

Uncrated 26" (660mm)
Crated 31" (787mm)

SHIPPING INFORMATION

Approx. Weight
 Single 950 lbs. (431kg)
 Double 1850 lbs. (839kg)

Crate Size

66" (1676mm) x 54.6" (1384mm) x 31" (787mm)
 (1 crate per section)