



PANINI PREMIUM CONCEPT

ELECTRIC PREMIUM PANINI PRESS

- ❑ Unique 2 in 1 cooking solution
 - ❑ Selector switch for panini press or bottom plate only operations
- ❑ Enameled high conductivity cast iron plates for easy cleaning
- ❑ Fast preheat time - up to 536°F in 8 1/2 minutes (instead of 14 1/2 minutes standard)
- ❑ Thermostatically controlled up to 570°F with on/off feature
- ❑ Special built-in heating system provides consistent temperature for rapid and even cooking from edges to center

DIABLO PREMIUM



- ❑ Self-balancing, adjustable top plate with heavy duty handle
- ❑ Built-in, removable drip/crumb tray
- ❑ Programmable electronic timer (3 settings)
- ❑ Stainless steel exterior for lasting service

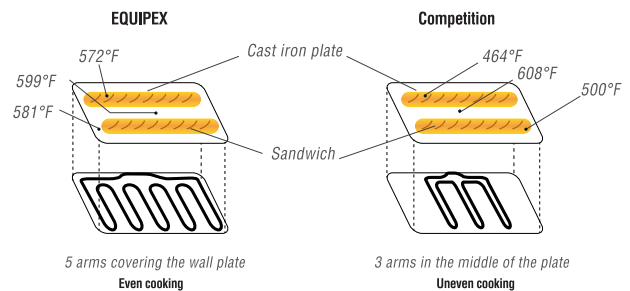

PANINI PREMIUM



120 V or 208/240 V

OPTIONS:

- * grooved top and bottom plates
- * grooved top / smooth bottom plates

DIABLO PREMIUM



208/240 V

OPTIONS:

- * grooved top and bottom plates
- * grooved top / smooth bottom plates



100 NIANTIC AVENUE; SUITE 104 PROVIDENCE, RI 02907
 TEL: (401)273-3300 FAX: (401)273-3328 E-mail: sales@equipex.com
 www.equipex.com





ELECTRIC PANINI PREMIUM PRESS

PANINI PREMIUM

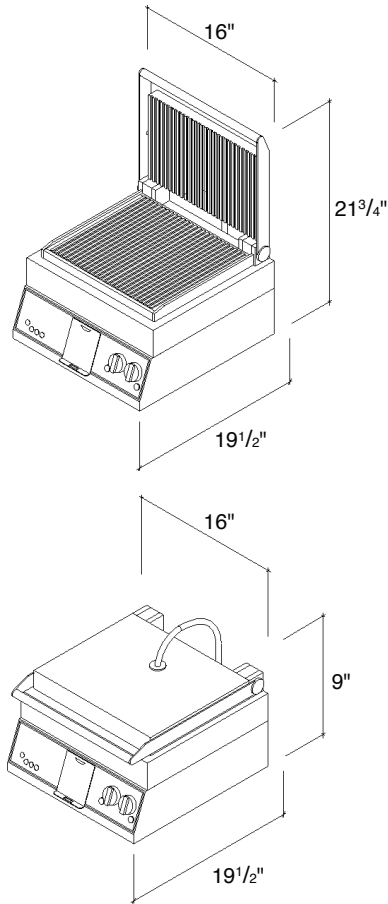

DIABLO PREMIUM

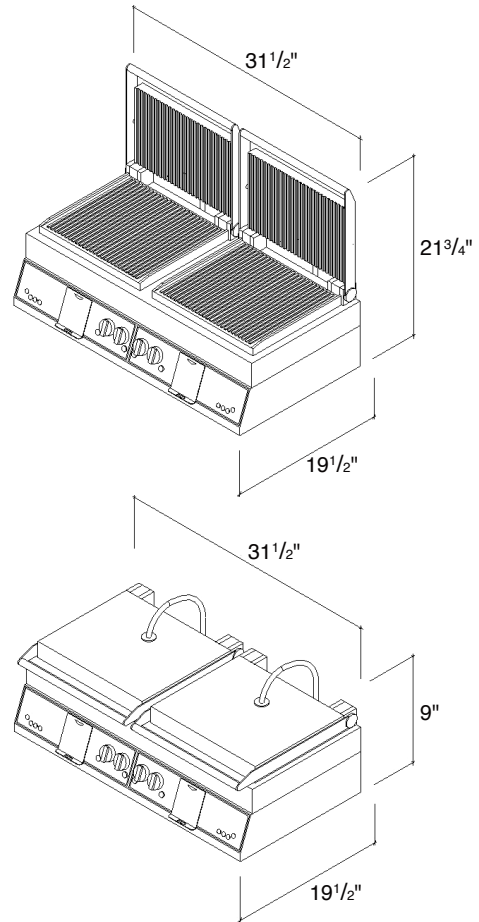

SPECIFICATIONS

INSTALLATION CLEARANCE: 2" EACH SIDE

MODEL	ELECTRICAL	DIMENSIONS	WORK SURFACE	SHIPPING WEIGHT	NEMA PLUG
DIABLO PREMIUM	208/240V, 1PH 6.5KW, 24/27 Amps	31 1/2"Wx19 1/2"Dx21 3/4"H	14"Wx9 1/2"D Two (2)	155 lbs	6-50 P
PANINI PREMIUM	120V, 1PH, 1.75KW, 15 Amps 208/240V, 1PH, 3KW 12/14 Amps	16"Wx19 1/2"Dx21 3/4"H	14"Wx9 1/2"D	73 lbs	5-15 P 6-20 P

WARRANTY: Limited one year parts and labor



100 NIANTIC AVENUE; SUITE 104 PROVIDENCE, RI 02907
 TEL: (401)273-3300 FAX: (401)273-3328 E-mail: sales@equipex.com
 www.equipex.com

