



STAINLESS STEEL EVERYDAY BUFFET HOT FOOD TABLES WITH ENCLOSED BASE



B3-120-B-SB Shown

FEATURES:

4" Swivel Casters, with two brakes
Double sided sneeze guard & side panels
Fiberglass insulation

For Use with Optional Spillage Pans



MATERIAL:

TOP: 20 gauge #304 stainless steel with die stamped pan openings. (12" x 20")

BODY: 20 gauge steel available in matte black vinyl clad

SNEEZE GUARD: 1/4" Thermoplastic Polymer

INSULATION: Fiberglass insulation

HEAT COMPARTMENT: 20 gauge aluminum with exposed dome shape element (S/S wells optional)

LINERS: 8" deep, 22 Gauge galvanized or #302 stainless steel. Requires spillage pans, Add

Model # SP-A (Aluminum) or **Model # SP-S** (S/S)

ELECTRICAL:

Single phase wiring

120V units yield 500 Watts

208V/240V dual voltage units yield 750 Watts at 208V and

1000 Watts at 240V

6' electrical cord with plug

Infinite control knobs

Indicator lights

Upgrade 240 volt units to

3 Phase wiring - **Model SU-72**

Item #: _____ Qty #: _____
Model #: _____
Project #: _____

GALVANIZED LINERS	STAINLESS STEEL LINERS	Length	# of Wells	Weight (lbs.)	Cubic Feet	Volts	Amps	Watts	NEMA Plug
B2-120-B-SB	B2-120-B-S-SB	31-13/16"	2	135	39	120	8.33	1000	5-20P
B3-120-B-SB	B3-120-B-S-SB	47-1/8"	3	170	56	120	12.50	1500	5-20P
B4-120-B-SB	B4-120-B-S-SB	62-7/16"	4	310	73	120	16.67	2000	L5-30P
B2-240-B-SB	B2-240-B-S-SB	31-13/16"	2	135	39	208/240	7.21/8.33	1500/2000	6-20P
B3-240-B-SB	B3-240-B-S-SB	47-1/8"	3	170	56	208/240	10.82/12.50	2250/3000	6-20P
B4-240-B-SB	B4-240-B-S-SB	62-7/16"	4	310	73	208/240	14.42/16.67	3000/4000	L6-30P
B5-240-B-SB	B5-240-B-S-SB	77-3/4"	5	390	90	208/240	18.03/20.84	3750/5000	L6-30P

NOTE: Units are not designed to cook or heat frozen or refrigerated foods. Food placed in tables should already be hot, and the table will maintain the proper temperatures

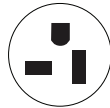

NEMA 5-20P



NEMA 6-20P



NEMA L5-30P



NEMA L6-30P

Optional Accessories



Stationary Shelf



Drop-Down Shelf



Stationary Shelf



Drop-Down Shelf

10" Wide Stainless Steel Tray Shelves

STATIONARY DROP-DOWN

Model	Model	Length	Approx Wt.	Cu. ft.
TTS-2	TTS-2D	31.8125"	14 lbs.	3
TTS-3	TTS-3D	47.125"	16 lbs.	4
TTS-4	TTS-4D	62.4375"	18lbs.	5
TTS-5	TTS-5D	77.75"	21 lbs.	6

Visit our website for more Everyday Buffet Accessories!

10" Wide Stainless Steel Tray Rails

STATIONARY DROP-DOWN

Model	Model	Length	Approx Wt.	Cu. ft.
TTR-2	TTR-2D	31.8125"	14 lbs.	3
TTR-3	TTR-3D	47.125"	16 lbs.	4
TTR-4	TTR-4D	62.4375"	18lbs.	5
TTR-5	TTR-5D	77.75"	21 lbs.	6



Customer Service Available To Assist You **1-800-645-3166** 8:30 am - 8:00 pm E.S.T.

For Orders & Customer Service:

Email: customer@advancetabco.com or Fax: 631-242-6900

For Smart Fabrication™ Quotes:

Email: smartfab@advancetabco.com or Fax: 631-586-2933

DIMENSIONS and SPECIFICATIONS

TOL ± .125"

ALL DIMENSIONS ARE TYPICAL

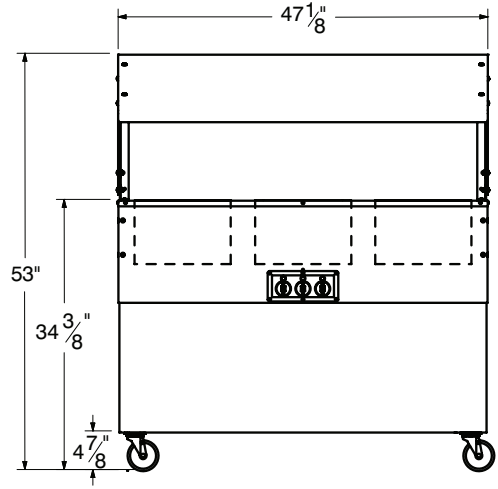
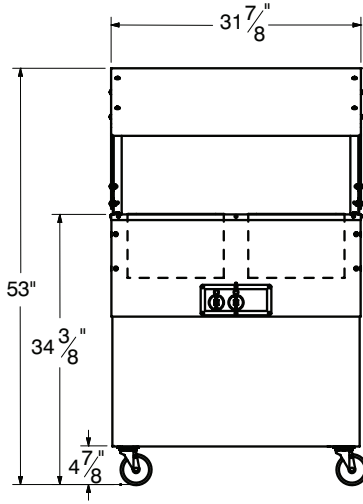
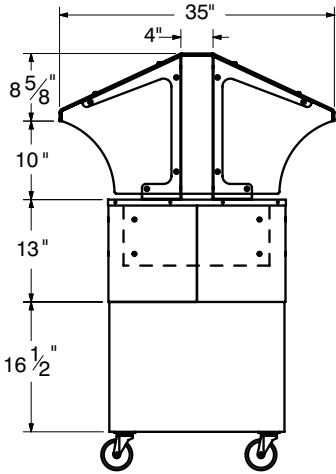
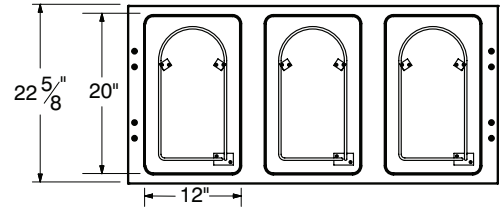
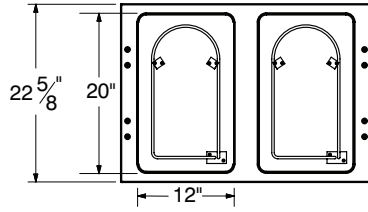

SIDE VIEW

2-Well

3-Well

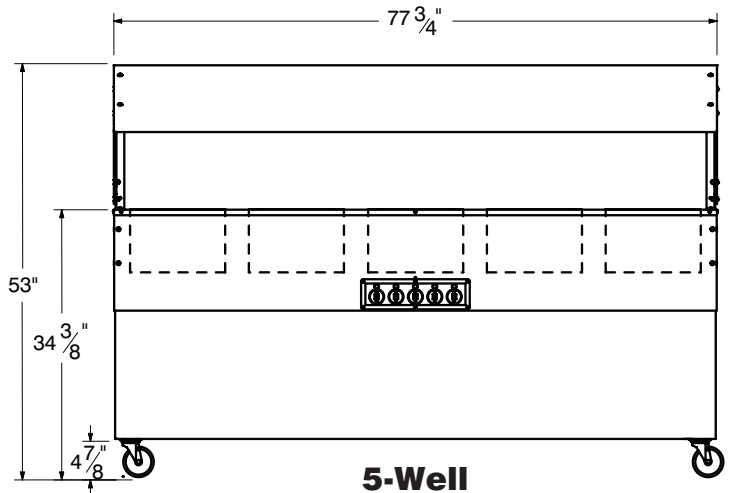
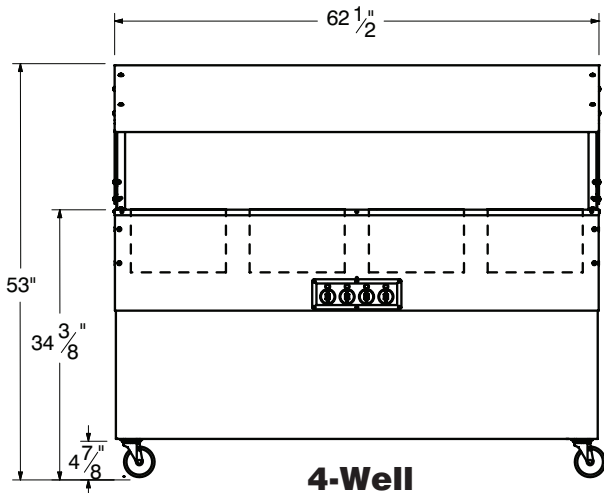
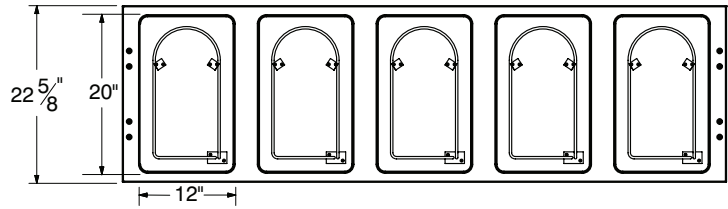
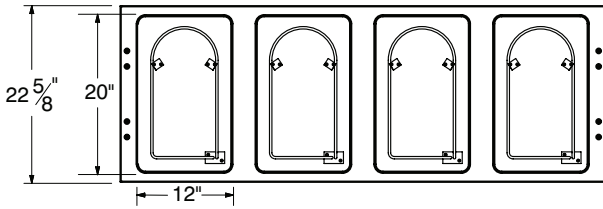

4-Well

5-Well



ADVANCE TABCO is constantly engaged in a program of improving our products. Therefore, we reserve the right to change specifications without prior notice.