

HEAVY DUTY PORTABLE BARS WITH DOORS

w/ ALL STAINLESS STEEL BARTENDER SIDE

Designed For **HEAVY DUTY** Use

Item #:	_____	Qty #:	_____
Model #:	_____		
Project #:	_____		



FEATURES:

- All stainless steel bartender side.
- 19" x 13-1/2" x 11" stainless steel insulated integral ice bin. Complete with drain & shut-off valve.
- Stainless steel speed rails.
- Center stainless steel panel for extra support.
- Hinged door with lock on left and right side of center support panel.
- Full perimeter bumpers.
- Four 5" heavy duty swivel casters (2 with brakes).
- Bottom shelf for glass rack storage.
- 7 Models** Includes above features with additional 7-circuit post mix cold plate in right ice bin.

MATERIAL:

- Top & Front:** Mica laminate, black finish
- Unit:** Stainless steel work top, back, sides & bottom
- Bartender Side:** Stainless steel
- Casters:** Rubber
- Speed Rails:** Stainless steel

Standard Model #	Wt.	Cold Plate Model #	Wt.	Size L x W x H	Storage Cabinet Dim. L x W x H	# Of Speed Rails	Bottle Capacity Per Speed Rail (750ml Bottles)	Bar Top Width	Cu. Ft.
AMD-5B	423	AMD-5B-7	448	62 1/4" x 28 1/8" x 46 5/8"	57 7/8" x 23 3/4" x 15 1/2"	2	10	12"	50
AMD-6B	464	AMD-6B-7	489	74 3/8" x 28 1/8" x 46 5/8"	69 7/8" x 23 3/4" x 15 1/2"	3	15	12"	60

CUSTOM EXTERIOR OPTIONS

Applied To Portable Bar Front And Sides ONLY, Unless Otherwise Specified



-LMP
Marula Pine Laminate



-LCW
Columbian Walnut Laminate



-LCM
Calcutta Marble Laminate



-SS
Stainless Steel Panels
(Includes Bar Top)



SU-81
Custom Laminate Of Your Choice
Consult Factory For Pricing & Details

Add Model Number At End Of Portable Bar Model Number When Ordering (Example: R-8-B-LCW)

DIMENSIONS and SPECIFICATIONS

TOL ± .125"

ALL DIMENSIONS ARE TYPICAL

AMD-5B

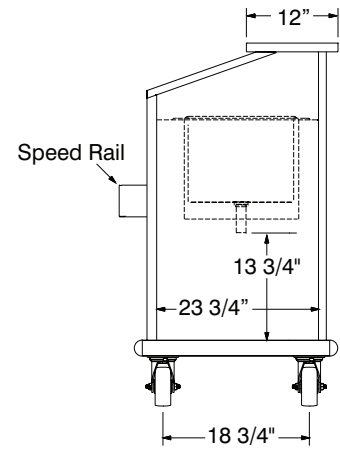
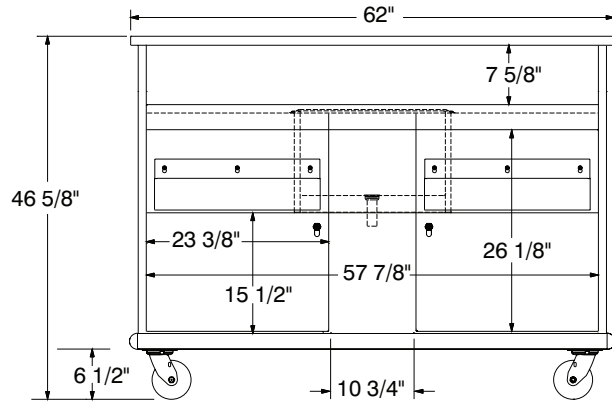
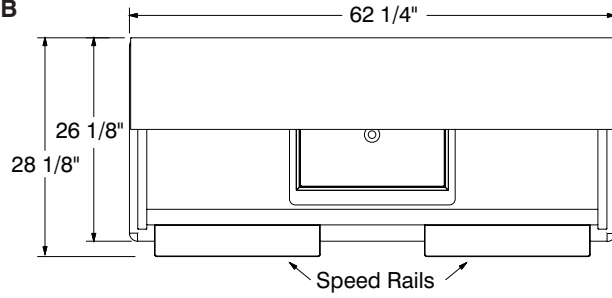

AMD-6B

