

Manual Control GRIDDLES

Features

- The Ikon Manual Control Griddles are available in 12", 24", 36", 48" & 60" widths, the continuous 30,000 BTU output per burner provides even heat to the 3/4" thick polished steel griddle plate
- Adjustable manual gas controls provide easy and safe operations
- Pilot light can be lit from the front for ease of use
- "U" shape burners provide even heat distribution every 12"
- 3/4" griddle plate
- 30,000 BTU/ burner
- Gas control knob every 12"
- All stainless steel cabinet
- Double wall insulated sides
- Widths: 12", 24", 36", 48", & 60"
- "Cool-to-the-touch" front s/s edge
- Back and side splash guards fully welded to griddle plate
- Flue located on back of unit for ample ventilation
- Adjustable stainless steel legs, non-skid feet
- Easy to remove 3-1/4" grease drawer with "weep hole" and baffle
- Grease trough is standard 4" spatula width
- Griddle is fully serviceable from the front
- **Available in Natural gas(NG) or Liquid propane(LP). A conversion kit is supplied with each unit**



IMG-12



IMG-24



IMG-36



IMG-48



IMG-60



Manual Control GRIDDLES

Dimensions in inches

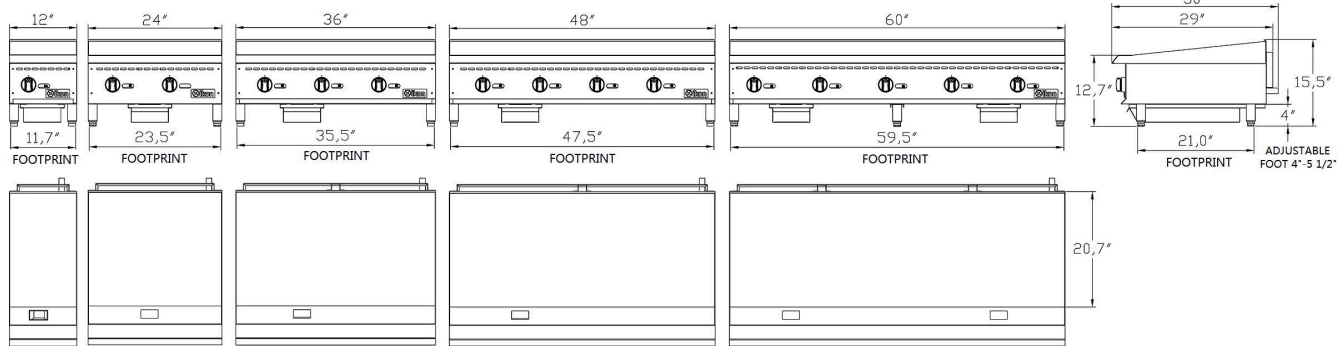

IMG-12

IMG-24

IMG-36

IMG-48

IMG-60

Specifications

Model	Footprint	Overall Dimensions	Weight	Shipping Dimensions	Shipping Weight
IMG-12	11.7"W x 21.0"D (53.4cm x 29.7cm)	12.0"W x 34.4"D x 15.5"H (30.5cm x 87.3cm x 39.4cm)	99 lbs (45kg)	16.2"W x 36.2"D x 19.3"H (41cm x 92cm x 49cm)	121 lbs (55kg)
IMG-24	23.5"W x 21.0"D (59.69cm x 53.3cm)	24.0"W x 34.4"D x 15.5"H (61.0cm x 87.3cm x 39.4cm)	156 lbs (71.0kg)	28.3"W x 36.2"D x 19.3"H (72cm x 92cm x 49cm)	196 lbs (89.0kg)
IMG-36	35.5"W x 21.0"D (90.2cm x 53.3cm)	36.0"W x 34.4"D x 15.5"H (91.4cm x 87.3cm x 39.4cm)	220 lbs (100.0kg)	40.6"W x 36.2"D x 19.3"H (103cm x 92cm x 49cm)	284 lbs (129.0kg)
IMG-48	47.5"W x 21.0"D (120.6cm x 53.43cm)	48.0"W x 34.4"D x 15.5"H (122.0cm x 87.3cm x 39.4cm)	277 lbs (126.0kg)	52.8"W x 36.2"D x 19.3"H (134cm x 92cm x 49cm)	355 lbs (161.0kg)
IMG-60	59.5"W x 21.0"D (151.1cm x 53.3cm)	60.0"W x 34.4"D x 15.5"H (152.4cm x 87.3cm x 39.4cm)	340 lbs (154kg)	64.8"W x 36.2"D x 19.3"H (164.5cm x 92cm x 49cm)	417 lbs (189.0kg)

Please Note: These items are shipped on a pallet and are crated for protection during LTL shipment. Overall Dimensions include the gas regulator located on the back of the unit



Model	Cooking Area	Controls	Number of Burners	BTU's per Burner	Total BTU's
IMG-12	12"W x 20.5"D	Manual	1	30,000	30,000
IMG-24	24"W x 20.5"D	Manual	2	30,000	60,000
IMG-36	36"W x 20.5"D	Manual	3	30,000	90,000
IMG-48	48"W x 20.5"D	Manual	4	30,000	120,000
IMG-60	60"W x 20.5"D	Manual	5	30,000	150,000

GAS REQUIREMENTS

- Natural Gas or Liquid Propane (LP) Gas main supply required
- A conversion kit is supplied with each unit. In order to avoid any warranty issues, conversion of your unit must be completed by an authorized Ikon service agent.
- 3/4" NPT gas connection
- 30,000 BTU's per burner
- One pilot light per burner
- Natural gas 4" W.C., LP gas 10" W.C.