

V-Series 60 Qt. Mixer

The kitchen workhorse, for a wide range of heavy-duty mixing applications.



MODELS

- V60** 60 qt. Standard **V60PL** 60 qt. Power Lift
 V60P 60 qt. Pizza

STANDARD FEATURES

- Stainless steel top cover, planetary cover, bayonet shaft, bowl guard and legs
- IP32 rated
- Powerful 3 HP motor with variable speed drive and agitator speed range from 53 RPMs to 288 RPMs
- #12 attachment hub with 198 RPM speed
- No bowl adapters required for down-sizing bowls
- Hydraulic damper for easier bowl lowering, and single lever manually raises bowl and locks into position (V60, V60P)
- Front-mounted controls with 90-minute digital timer and emergency stop
- Power bowl lift (V60PL only)
- Durable powder coated finish on legs and outer surfaces not constructed of stainless steel
- High torque transmission
- Permanently lubricated planetary head & attachment hub case
- Bowl scraper bracket affixes to planetary head
- Grease lubricated, anti-friction ball bearings
- Patent-pending interlock prevents operation if guard is opened or bowl is lowered
- Overload protection and no volt release
- Non-skid rubber feet
- 6 foot cord
- ETL and NSF listed
- Made in Denmark

STANDARD ACCESSORIES

- Stainless steel bowl
- Stainless steel flat beater (V60/V60PL only)
- Stainless steel wire whip (V60/V60PL only)
- Stainless steel dough hook

WARRANTY

- Two-year parts and labor limited warranty

OPTIONAL ACCESSORIES/ATTACHMENTS

- 30 qt. bowl and attachments
- Bowl scraper - 30 qt. or 60 qt. options
- Bowl truck
- Stainless steel model
- Marine model

To select options see back

Approved by: _____

Date: _____



ETL listed
Conforms to UL Std 763
Certified to CSA Std C22.2 No. 195

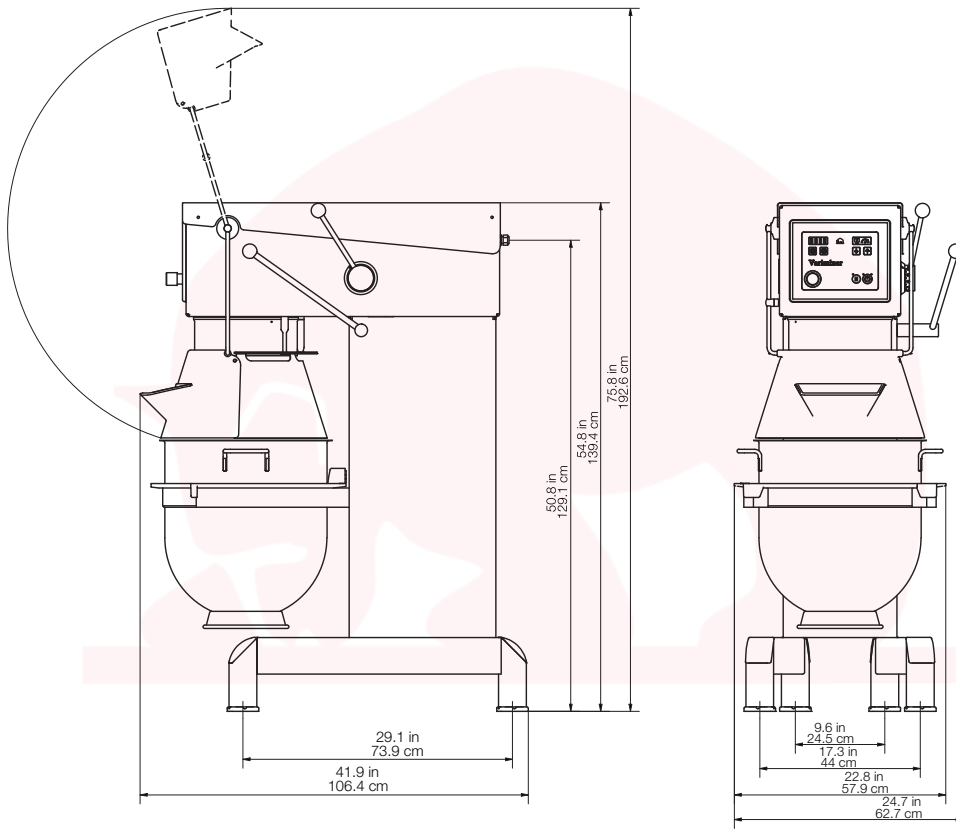

SPECIFICATIONS

Model	Motor	Volts	Amp	Plug Type	Mixing Speeds	Hub Speeds	IP Rating
V60	3 HP	208/60/1	10	--	53 - 288 RPMs	198 RPMs	IP32
V60PL	3 HP	208/60/3	6.4	--	53 - 288 RPMs	198 RPMs	IP32
V60P	3 HP	208/60/3	6.4	--	53 - 288 RPMs	198 RPMs	IP32

Delivered without plug. Specify voltage when ordering.

DIMENSIONS | SHIPPING INFORMATION

Reinforced carton for shipping. This product ships on a pallet. See dimensions below.

Model	Overall Dimensions	Net Wt.	Shipping Dimensions	Ship Wt.	Freight Class
V60 / V60PL / V60P	25.5" W x 40.5" D x 55.625" H (64.77 cm x 102.8 cm x 141.29 cm)	606 lbs. (275 kg)	32" W x 49" D x 70" H (81.28 cm x 124.4 cm x 177.8 cm)	707 lbs. (320.69 kg)	85 64 CU ft.

OPTIONAL/ADDITIONAL ACCESSORIES

- VBOWL30-60 30 qt. bowl
- VWHIP-30 30 qt. wire whip
- VSCRP-30 30 qt. scraper
- VWINGWHIP30-60 30 qt. wire whip
- VSCRP-60 60 qt. scraper
- XMCA-SS Meat grinder hub assembly
- VWINGWHIP-60 60 qt. wire whip
- XSVGH Slicer/Shredder housing
- VTRUCK-60 Bowl truck
- XSP Slicing plate
- VHOOK30-60 30 qt. hook
- L00783 Strip cutter
- VBEAT30-60 30 qt. beater
- L00670 Meat tenderizer

Product	Attachment	V60/PL	V60P
Bread Dough (65% AR)	Hook	90 lbs.	100 lbs.
Pizza Dough (50% AR)	Hook	75 lbs.	85 lbs.
Mashed Potatoes	Whip / Beater	46 lbs.	51 lbs.
Whipped Cream	Whip	12 qts.	12 qts.
Pancake Batter	Whip / Beater	28 qts.	33 qts.
Cookie Dough	Beater / Hook	50 lbs.	55 lbs.

Heavy-duty 60 qt. mixer with 3 HP motor and variable speed drive with agitator speed range from 53 to 288 RPMs. #12 attachment hub with 198 RPM speed. Stainless steel top cover, bayonet shaft and bowl guard. Non-stainless steel surfaces powder coated finish. Front-mounted controls with 90-minute digital timer. Bowl lowering lever with hydraulic damper. Permanently lubricated planetary head and attachment hub case. 6 ft. cord. Mixer is IP32 rated with ETL and NSF certification. Two-year parts and labor limited warranty.