

Teddy 5 Qt. Mixers

Sleek, compact design with powerful and quiet operation.



V5-R



V5-B



V5-S



V5-W

MODELS

- V5-R** 5 qt. Red **V5-B** 5 qt. Black
 V5-S 5 qt. Silver **V5-W** 5 qt. White

STANDARD FEATURES

- Powerful yet whisper-quiet .4 HP motor
- Variable speed drive with wide agitator speed range from 78 RPM to 422 RPMs
- Stainless steel bowl guard
- Bowl clamp securely holds bowl in place
- Aluminum frame with powder coated finish in red, black, silver or white
- Operated by either of two rotary knobs – one on each side
- Removable foodgrade polycarbonate bowl screen
- High torque, direct drive transmission
- Grease lubricated, anti-friction ball bearings
- Permanently lubricated planetary head
- Interlock automatically turns mixer off if mixer head is tilted
- Overload protection and no voltage release
- Provisions for bolting to counter or table
- NEMA 5-15P plug and 6 ft. cord
- ETL and NSF listed

STANDARD ACCESSORIES

- Stainless steel dough hook
- Stainless steel wire whip
- Stainless steel flat beater
- Stainless steel bowl
- Ingredient chute
- Polycarbonate bowl shield

OPTIONAL ACCESSORIES

- Plastic bowl lid

WARRANTY

- One-year parts & labor limited warranty

Approved by: _____
 Date: _____



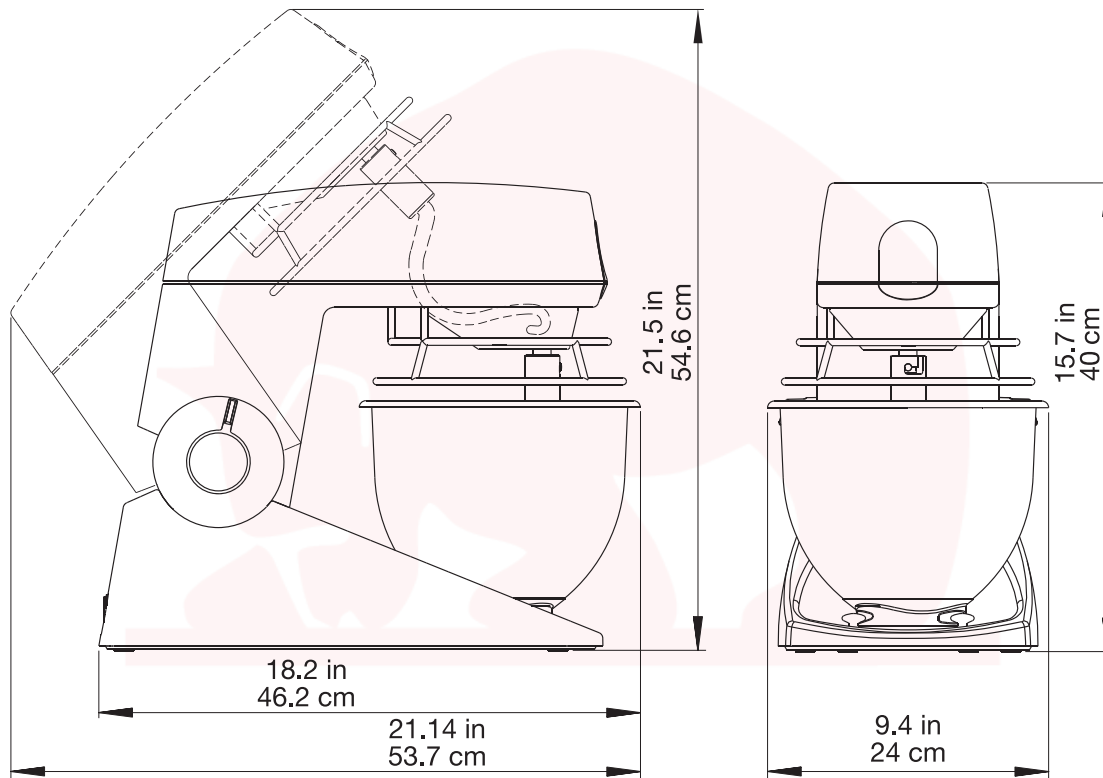

SPECIFICATIONS

| Model | Motor | Volts | Amp | Plug Type | Mixing Speeds | IP Rating |
|-------|-------|----------|-----|--------------|---------------|-----------|
| V5 | .4 HP | 120/60/1 | 3.0 | NEMA 5-15P ⚠ | 78 - 422 RPMs | 42 |

Other voltages upon request with 6 to 8 week lead time.

DIMENSIONS | SHIPPING INFORMATION

Reinforced carton for shipping. This product ships as a box parcel. See dimensions below.

| Model | Overall Dimensions | Net Wt. | Shipping Dimensions | Ship Wt. | Freight Class |
|-------|--|--------------------|--|--------------------|-----------------|
| V5 | 9.5" W x 21.66" D x 15.75" H (24.13 cm x 54 cm x 40 cm) | 40 lbs. (18 kg) | 11.875" W x 19.75" D x 19.75" H (30 cm x 50 cm x 50 cm) | 44 lbs. (20 kg) | 85 25 CU ft. |

STANDARD/OPTIONAL ACCESSORIES

- VBOWL-5 5 qt. bowl
- VHOOK-05 Dough hook
- VWHIP-05 Wire whip
- VBEAT-05SS Stainless steel flat beater
- VRING-05 Bowl shield
- VCHUTE-05 Ingredient chute
- VBLID-05 Bowl lid

| Product | Attachment | Capacity |
|-------------------|---------------|----------|
| Mashed Potatoes | Whip / Beater | 4 lbs. |
| Whipped Cream | Whip | 1 qt. |
| Muffins | Beater | 5 lbs. |
| Pancake Batter | Whip / Beater | 2 qts. |
| Cookie Dough | Beater / Hook | 3 lbs. |
| Donuts, Cake | Beater | 5 lbs. |
| Bread Dough (65%) | Hook | 5 lbs. |
| Pizza Dough (50%) | Hook | 4 lbs. |

Sleek aluminum, powder coated 5 qt. mixer with .4 HP motor. Variable speed drive from 78 to 422 RPMs. Permanently lubricated planetary head. Interlocked tilting head, overload protection and no volt release offer operator protection. 6 ft. cord and NEMA 5-15P plug. Provisions for bolting to counter or table. cETLus and NSF listed. Backed by 1-year parts and labor limited warranty.