

Kodiak Lite 10 Qt. Mixers

Mixing simplified with this ergonomic and hygienic heavy-duty mixer.



MODELS

V10KLT 10 qt. Bench **V10KLF** 10 qt. Floor

STANDARD FEATURES

- Stainless steel frame with smooth, easy to clean surfaces
- IP44 rated, protected from water splashing
- Powerful 1 HP motor with variable speed drive
- Wide agitator speed range from 72 RPM to 451 RPMs
- Magnetic removable foodgrade polycarbonate bowl shield
- Front-facing control panel for easy visibility; includes timer, automatic speed regulation and emergency stop
- Four height adjustable legs - floor model
- Two height adjustable legs - bench model
- High torque transmission
- Grease lubricated, anti-friction ball bearings and permanently lubricated planetary head
- Locking pin on tools instead of shaft for economical replacement
- Integrated bowl scraper bayonet – no brackets required
- Interlock automatically turns the mixer off if bowl shield is not in place or bowl is lowered
- Overload protection and no volt release
- 6 foot cord
- ETL and NSF listed
- Made in Denmark

STANDARD ACCESSORIES

- Stainless steel dough hook
- Stainless steel wire whip
- Stainless steel flat beater
- Stainless steel bowl

WARRANTY

- Two-year parts & labor limited warranty

OPTIONAL ACCESSORIES/ATTACHMENTS

- Bowl scraper
- Tool rack

To select options see back



ETL listed
Conforms to UL Std 763
Certified to CSA Std C22.2 No. 195

Approved by: _____

Date: _____

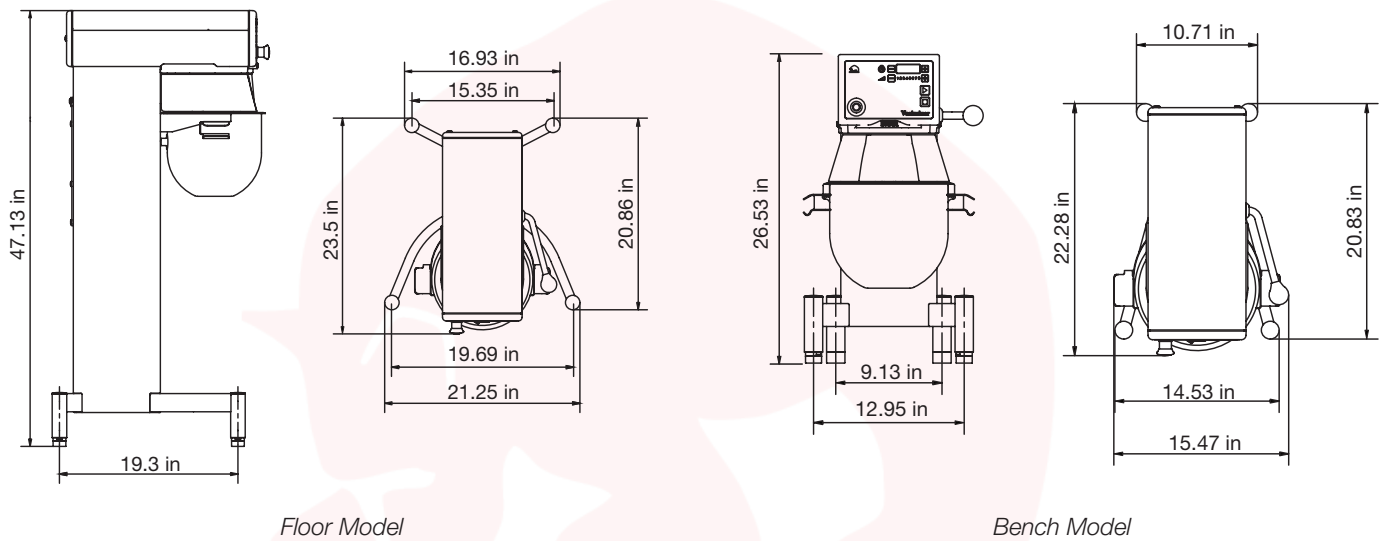

Floor Model

Bench Model

SPECIFICATIONS

Model	Watts	Volts	Amp	Plug Type	Mixing Speeds	IP Rating
V10KLT	700	120/60/1	15.7	NEMA 5-15P ⚡	72 - 451 RPMs	IP44
V10KLF	700	120/60/1	15.7	NEMA 5-15P ⚡	72 - 451 RPMs	IP44

DIMENSIONS | SHIPPING INFORMATION

Reinforced carton for shipping. This product ships on a pallet. See dimensions below.

Model	Overall Dimensions	Net Wt.	Shipping Dimensions	Ship Wt.	Freight Class
V10KLT	15.47" W x 22.3" D x 26.54" H (39.3 cm x 56.6 cm x 67.4 cm)	110.2 lbs. (50 kg)	18.8" W x 25.9" D x 35.04" H (47.7 cm x 66 cm x 89 cm)	132.27 lbs. (60 kg)	85 10 CU ft.
V10KLF	21.26" W x 23.5" D x 47.13" H (54 cm x 59.7 cm x 119.7 cm)	264.56 lbs. (120 kg)	26.7" W x 26.7" D x 55.9" H (68 cm x 68 cm x 142 cm)	286.6 lbs. (130 kg)	85 23 CU ft.

OPTIONAL/ADDITIONAL ACCESSORIES

- VSCRP-10K 10 qt. bowl scraper
- VTOOLRACK20-30 Tool rack
- XTABLE for V10KLT – 24" x 30" x 24" mixer table with undershelf

Product	Attachment	Capacity
Egg White	Whip	.5 qts
Whipped Cream	Whip	2.5 qt.
Cake Batter	Beater	11 lbs.
Mashed Potatoes	Beater	8.8 lbs.
Meatball Mixture	Beater	13 lbs.
Pizza Dough (50% AR)	Hook	11 lbs.
Bread Dough (60% AR)	Hook	11 lbs.

Heavy-duty stainless steel 10 qt. mixer with 1 HP motor, high-torque transmission and variable speed drive from 72 to 451 RPMs. IP44 rated. Mixer has front-facing control panel with timer, automatic speed regulation and emergency stop. Mixer has grease lubricated, anti-friction ball bearings and permanently lubricated planetary head & attachment hub case. Overload protection, interlocked bowl and bowl shield and no volt release. cETLus and NSF listed. 2-year parts & labor limited warranty.