



HAND BLENDER XM-52

Professional immersion blender. 1.1 Hp.



- ✓ Approved by NSF: guaranteed safety and hygiene.

INCLUDES

- ✓ Fixed speed motor block.
- ✓ MA-52 mixer arm.
- ✓ Wall mount.

OPTIONAL

- MA-51 mixer arm.

ACCESSORIES

- Mixer arms MA-50
- "Quick fix" Bowl clamp

SPECIFICATIONS

Total loading: 1.1 Hp
 Maximum recipient capacity: 127 qt
 Motor speed: 12000 rpm
 Blade diameter: 2.36 "
 Blade guard diameter: 4 "

Length

Liquidising arm length: 20.7 "
 Total length: 34 "

Net weight: 10.69 lbs
 Noise level (1m.): <80 dB(A)

Crated dimensions

22.6 x 17.9 x 5.1 "
 Gross weight: 11.9 lbs.

AVAILABLE MODELS

3030841 Immersion blender XM-52 120/50-60/1

* Ask for special versions availability

SALES DESCRIPTION

- ✓ Fixed speed motor block.
- ✓ 20.7 " detachable arm.
- ✓ Designed for continuous use in recipients of up to 127 qt.

All-in-one

- ✓ Professional hand blender designed for carrying out different preparations without the need for add-on tools.
- ✓ Professional Y-blade, made from tempered steel and with a long-duration cutting edge.
- ✓ Fixed speed.
- ✓ Designed to work in recipients of up to 120 litres.

Maximum comfort for the user

- ✓ Logical and manageable size.
- ✓ Ergo-design & bi-mat-grip: external casing made in two materials for an ergonomic hold. Anti-slip grip. Optimum inclination of handle, minimising fatigue.
- ✓ Click-on-arm: detachable arm with fast and secure closure.
- ✓ Hood designed to avoid splashes.
- ✓ Intuitive use: very simple operation. LED warning light in two colours to indicate the status of the machine.
- ✓ Possibility of continuous operation.

Built to last

- ✓ Professional performance: capable of carrying out prolonged work without the casing overheating.
- ✓ Life-plus: equipped with a motor which has passed all of the most demanding usage tests.
- ✓ Studied geometry: casing designed to avoid rolling and falling.
- ✓ Easy to clean: detachable arm, can be cleaned under the tap.





HAND BLENDER XM-52

Professional immersion blender. 1.1 Hp.



DYNAMIC PREPARATION
COMMERCIAL HAND BLENDERS

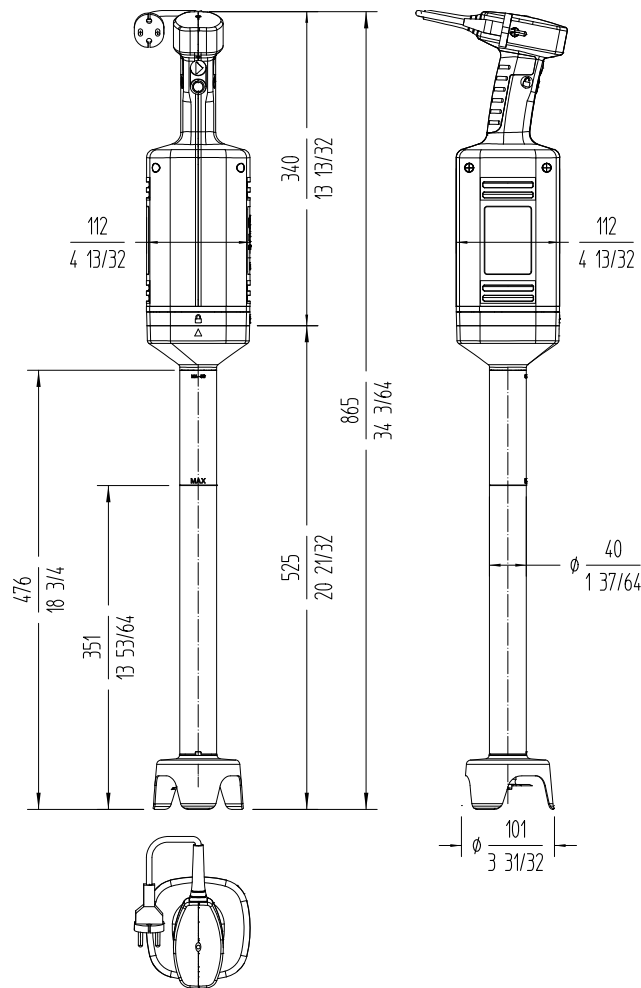

sammic | www.sammic.us
Food Service Equipment Manufacturer

usa@sammic.com
1225 Hartrey Avenue
60202-1056 Evanston, IL

phone +1 (224) 307-2232
toll free +1 844 275 3848



Project	Date
Item	Qty
Approved	

product sheet
updated 02/24/22