



VEGETABLE PREPARATION MACHINE CA-61

High-production commercial Vegetable Processor, up to 2,200 lbs./h.



- ✓ The electronic command panel is very intuitive.

Maintenance, safety, hygiene

- ✓ Hopper and lid easily removable for cleaning.
- ✓ Combination of safety systems: hopper, cover, power switch.
- ✓ Appliance certified by NSF International (regulations on hygiene, cleaning and materials suitable for contact with foods).
- ✓ 100% tested.

INCLUDES

- ✓ Two-speed motor block.
- ✓ High production semi-automatic hopper.

ACCESSORIES

- FCC Curved Slicing Discs
- FCO Rippled Slicing Discs
- FFC Chipping Grids
- FMC Dicing Grids
- FR Shredding & Grating Discs
- Long vegetable attachment
- Disc and Grid Packs
- Disc and Grid Holder
- Stand-trolley
- Large Capacity Attachment
- Grid Cleaning Kit
- FC-D Slicing Discs
- SH Shredding & Grating Discs ::
NEW: Detachable without tools & dishwasher safe

SALES DESCRIPTION

Single-speed motor block + high-production semi-automatic hopper.

A perfect cut

- ✓ High precision adjustments to obtain a uniform and excellent-quality cut.
- ✓ It can be fitted with a wide range of discs and grids of the highest cutting quality.
- ✓ Combining these accessories together to obtain more than 70 different types of cuts and grating grades.
- ✓ Head equipped with high ejector: enables a higher quantity of product to be shifted.

Built to last

- ✓ Made from stainless steel and materials of the highest quality and suitable for food contact: stainless steel motor block and hopper and food-grade aluminium head.
- ✓ High power asynchronous motor.

Maximum comfort for the user

- ✓ Ergonomic design. Maximum comfort for the user.
- ✓ Lateral product output: requires less space on the worktop and guides the product, avoiding splashes.



sammic | www.sammic.us
Food Service Equipment Manufacturer

usa@sammic.com
1225 Hartrey Avenue
60202-1056 Evanston, IL

phone +1 (224) 307-2232
toll free +1 844 275 3848



Project	Date
Item	Qty
Approved	

product sheet
updated 11/29/21

DYNAMIC PREPARATION
COMMERCIAL VEGETABLE PREPARATION MACHINES



VEGETABLE PREPARATION MACHINE CA-61

High-production commercial Vegetable Processor, up to 2,200 lbs./h.



SPECIFICATIONS

Hourly production (pieces): 1000 lbs. - 2200 lbs.

Inlet opening: 42.4 in2

Disc diameter: -- "

Motor speed: 365 rpm

Total loading: 1.5 Hp

Noise level (1m.): <70 dB(A)

Background noise: 32 dB(A)

External dimensions (WxDxH)

Width: 16.9 "

Depth: 16.5 "

Height: 31.9 "

Crated dimensions

18.9 x 18.1 x 29.1 "

Volume Packed: 0.17 m³

Gross weight: 72.8 lbs.

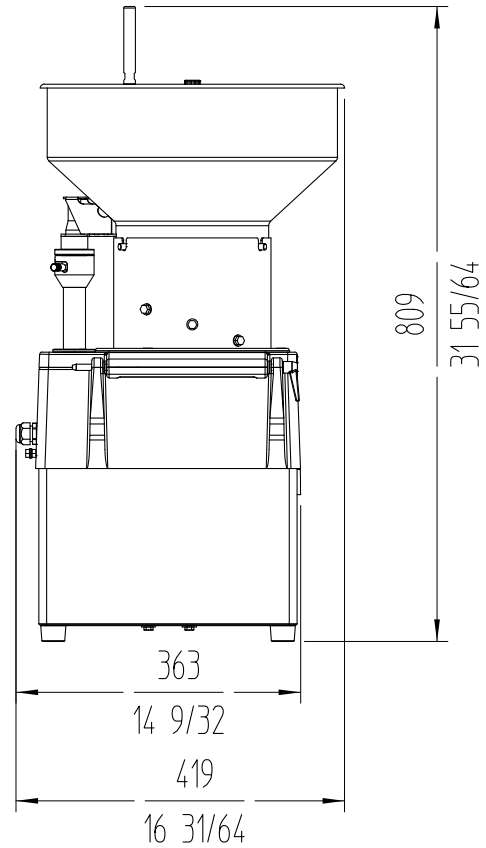
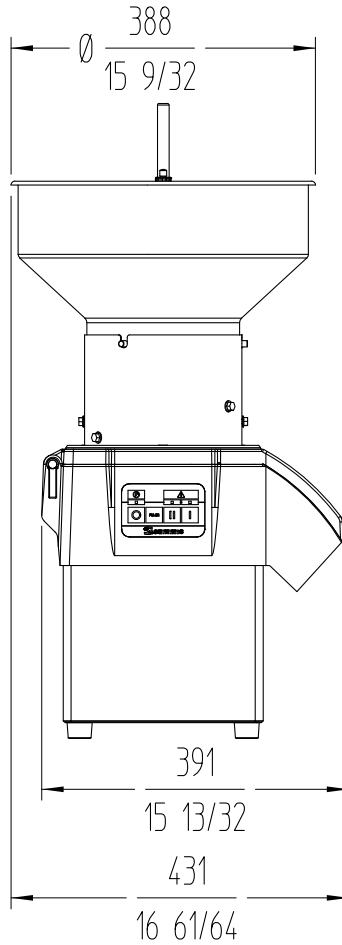

DYNAMIC PREPARATION
COMMERCIAL VEGETABLE PREPARATION MACHINES

AVAILABLE MODELS

1050741 Vegetable preparation machine CA-61 120/60/1

* Ask for special versions availability

sammic www.sammic.us Food Service Equipment Manufacturer usa@sammic.com phone +1 (224) 307-2232 1225 Hartrey Avenue toll free +1 844 275 3848 60202-1056 Evanston, IL		Project	Date
		Item	Qty
		Approved	

product sheet
updated 11/29/21