



The Signature of Quality

FEDERAL INDUSTRIES

A Standex Company

215 Federal Avenue
Belleville, Wisconsin 53508-9201

Phone: 800-356-4206

Fax: 608-424-3234

Email: Geninfo@Federalind.com

Website: Federalind.com

Project Name: _____

Item #: _____

Model #: _____ Qty: _____

Approval: _____

AIA #

SIS #

VISION SERIES - High Profile Self-Serve Non- Refrigerated Merchandiser - 60"

Designed with impulse sales in mind. Get maximum return from an attention-grabbing merchandiser and increase profits.



Model VNSS3660C Shown
Solid Ends Shown

MODEL	DIMENSIONS (Includes End Panels)
<input type="checkbox"/> VNSS3660C	36 x 33 x 60 (in) 914 x 838 x 1524 (mm)
<input type="checkbox"/> VNSS4860C	47.25 x 33 x 60 (in) 1200 x 838 x 1524 (mm)
<input type="checkbox"/> VNSS6060C	59.25 x 33 x 60 (in) 1505 x 838 x 1524 (mm)
<input type="checkbox"/> VNSS7260C	71.25 x 33 x 60 (in) 1810 x 838 x 1524 (mm)

STANDARD FEATURES

Model Features

- Welded powder coated steel base fabrication
- Choice of six standard laminates on exterior
- Black powder coated metal front and rear grill
- Stainless steel display deck
- Glass ends or black solid ends
- Black interior back panel
- Moisture resistant end panel construction
- Cord & Plug
- Leveling Legs

Shelving

- Two tiers of adjustable black metal shelves with price tag molding. Shelves can be flat or slanted downwards at 10°

Lighting

- 3500K LED top light,

Agency Approvals

- UL, C-UL

OPTIONAL ACCESSORIES

- Special External Laminate Finish
- Graphics Package
- White Interior (Including Shelving)
- Stainless Steel Interior (Including Shelves)
- Stainless Steel Exterior Finish
- Stainless Steel Shelves
- Reflective End Glass
- Peg Hooks
- Sliding Rear Access Doors (hinged on 36" cases)
- Roll-up Security Cover (Square End Profile)
- LED Lights Below Shelves
- Additional Lighted (LED) Shelf
- 2 1/2" (63.5mm) recessed or 4" (101.6mm) Casters (Cord Included)
- Legs, 6", (152mm)
- Skirt with Casters or Legs
- Joining Kit for Continuous Line-Ups
- Removable Security Cover
- Solid Right/Left End Panels (mirrored)

*Additional options available on the website and price list.



WARRANTY*
One year Parts and Labor
2nd thru 5th year part only
service compressor
(U.S.A. and Canada)

Note: Information is subject to change at any time. Visit www.federalind.com for the most current specs.

AIA #	VISION SERIES - High Profile Self-Serve Non- Refrigerated Merchandiser - 60"
SIS #	Product Specifications

Zone	Intended Product To Be Displayed	
All	Non-Refrigerated Package Products	

DIMENSION: xx"/(mm)
DIMENSION TOLERANCE +/- 0.25 (6.4)

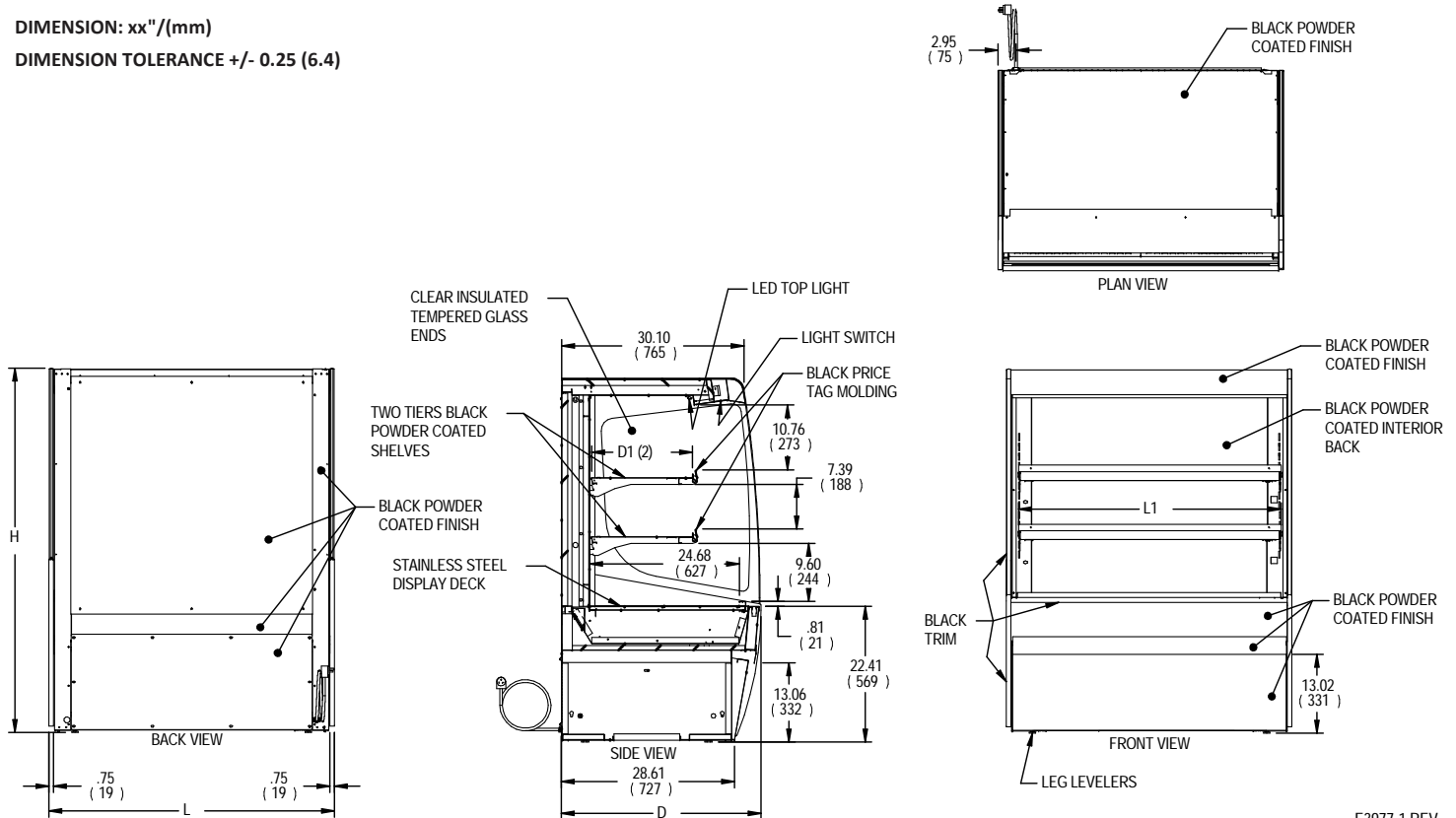

E3977-1 REV.

MODEL	DIMENSIONS			SHELVING		INTERIOR VOLUME CU FT	STANDARD CONNECTION CORD & PLUG			SHIP WEIGHT	
	L	D	H	# OF TIERS	L1		D1	2 WIRE + GROUND			NEMA CORD & PLUG
	in	in	in		in		in	120/60/1			
	mm	mm	mm		mm		mm	AMPS	MAX FUSE SIZE		
VNSS3660C	36	33	60	2	32.25	16.634	1.5	15	NEMA 5-15P	LBS	
	914	838	1524		819	423				KILO	
VNSS4860C	47.25	33	60	2	43.25	16.634	1.5	15	NEMA 5-15P	LBS	
	1200	838	1524		1099	423				KILO	
VNSS6060C	59.25	33	60	2	55.25	16.634	2.0	15	NEMA 5-15P	LBS	
	1505	838	1524		1403	423				KILO	
VNSS7260C	71.25	33	60	2	67.25	16.634	2.0	15	NEMA 5-15P	LBS	
	1810	838	1524		1708	423				KILO	

• Due to continuing engineering improvements, specifications are subject to change without notice.



FEDERAL INDUSTRIES
 A Standex Company
 215 Federal Avenue Belleville, Wisconsin 53508-9201

Phone: 800-356-4206
Fax: 608-424-3234
Email: Geninfo@Federalind.com
Website: Federalind.com