



The Signature of Quality

FEDERAL INDUSTRIES

A Standex Company
215 Federal Avenue
Belleville, WI 53508-9201

Phone: 800-356-4206
Fax: 608-424-3234
Email: geninfo@federalind.com
Website: www.federalind.com

Project Name: _____

Item #: _____

Model #: _____ Qty: _____

Approval: _____

AIA#

SIS#

ELEMENTS CURVED GLASS REFRIGERATED DELI CASE

Curved-glass styling with presentation and value in mind without sacrificing performance.



MODEL	LENGTH (Includes End Panels)
<input type="checkbox"/> ECGR50CD	50.13 x 35.31 x 48 (in) 1273 x 897 x 1219 (mm)
<input type="checkbox"/> ECGR59CD	59.13 x 35.31 x 48 (in) 1502 x 897 x 1219 (mm)
<input type="checkbox"/> ECGR77CD	77.13 x 35.31 x 48 (in) 1959 x 897 x 1219 (mm)

STANDARD FEATURES

Model Features

- Curved glass.
- Tempered thermopane tilt-out front glass.
- Tempered thermopane glass ends and doors.
- Removable sliding rear doors, shelf light, shelf supports, and shelf.
- Steel base construction, textured black powder coat finish.
- Stainless steel top and sides.
- Removable stainless steel display deck.
- Light switch and adjustable temperature control.
- Cord and plug.

Refrigeration

- Thermometer.
- Condensate evaporator.
- Average case temperature of 38° (3.3°C) to 40° F (4.4°C)
- Rear access to refrigeration system.
- R513a Refrigerant.

Shelving

- Adjustable full-length stainless steel lighted mezzanine shelf, can also be tilted.

Lighting

- 3000K LED top light and shelf lights.
- DLC Certified, IP66 rated.

Agency Approvals

- UL Safety and UL Sanitation Listed
- DOE 2017 Compliant



WARRANTY*
One year Parts and Labor
2nd thru 5th year part
only service compressor
(U.S.A and Canada)

Note: Information is subject to change at any time.
Visit www.federalind.com for the most current specs.

AIA#

ELEMENTS CURVED GLASS REFRIGERATED DELI CASE

SIS#

Product Specifications

Intended Environment: Type I - Designed to operate in maximum ambient conditions of 75°F (24°C) and 55% relative humidity unless noted otherwise in system information below.

Zone	Intended Product To Be Displayed	Avg Prod Temp °F/°C
All	Packaged Refrigerated Products	38°F / (3.3°C)

DIMENSION: xx"/(mm)

DIMENSION TOLERANCE +/- 0.19 (4.8)

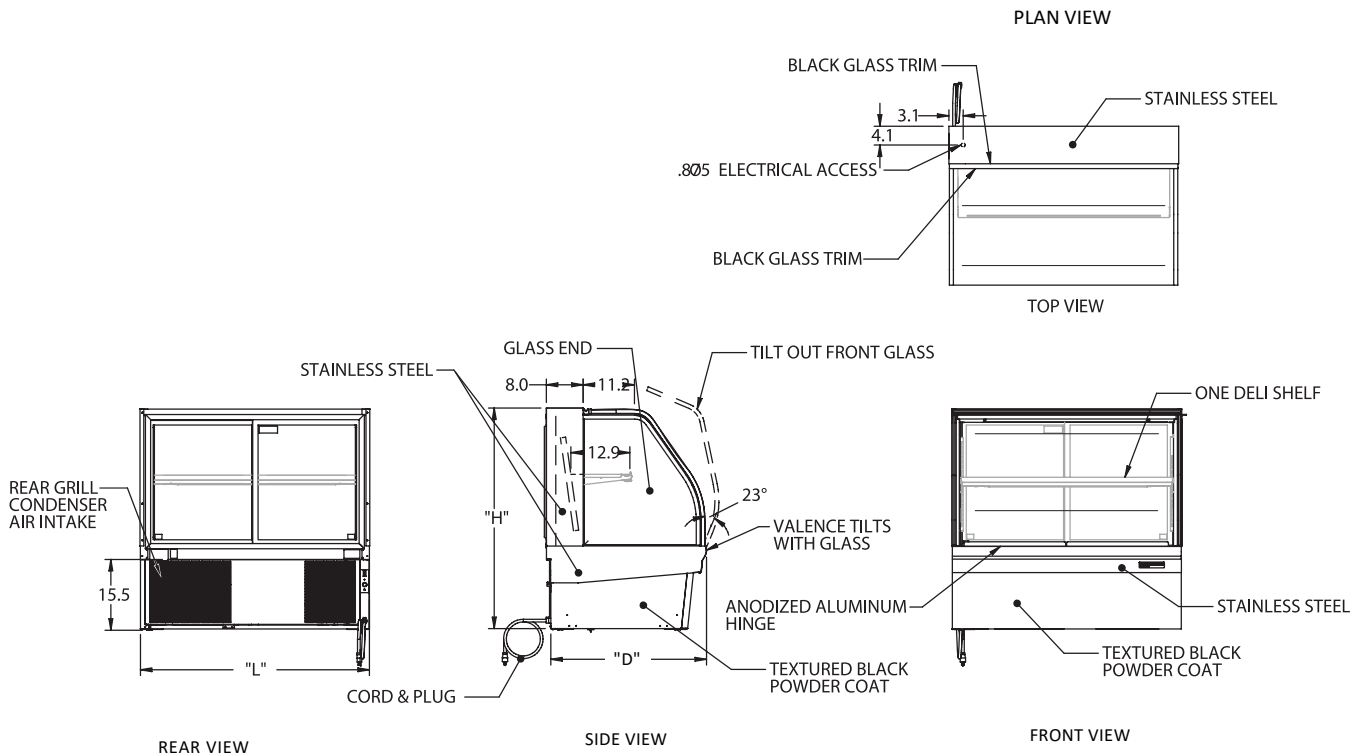

MODEL	DIMENSIONS				SHIPPING WHT		SELF-CONTAINED 120/60/1	NEMA PLUG
	L	D	H1	UNITS	LBS	KILO		
ECGR50CD	50.13	35.31	48	in.	620	281	1/2 HP - 10.5 AMP	NEMA 5-15P
	1273	897	1219	mm.				
ECGR59CD	59.13	35.31	48	in.	650	295	1/2 HP - 11.6 AMP	NEMA 5-15P
	1502	897	1219	mm.				
ECGR77CD	77.13	35.31	48	in.	870	395	3/4 HP - 14.2 AMP	NEMA 5-20P
	1959	897	1219	mm.				

- If a GFCI circuit is required, a GFCI Breaker Must be used instead of GFCI receptacle.
- Refrigerated cases are designed to operate in a maximum of 75°F (24°C) ambient and 55% relative humidity.
- Due to continuing engineering improvements, specifications are subject to change without notice.



The Signature of Quality®

FEDERAL INDUSTRIES

A Standex Company

215 Federal Avenue, Belleville, Wisconsin 53508-9201

Phone: 800-356-4206

Fax: 608-424-3234

Email: Geninfo@Federalind.com

Website: Federalind.com