



Project _____
 AIA # _____ SIS # _____
 Item # _____ Quantity _____ C.S.I. Section 114000



DEALERS CHOICE PREP TABLES

UPT SERIES

Compact Sandwich Prep Tables with
 Raised Cover/Self-Contained
 UPT 72" Wide Models



STANDARD PRODUCT FEATURES

- High Quality Stainless Steel Exterior Top, Sides & Doors
- Durable, Corrosion Resistant Anodized Aluminum Interior
- Provides NSF Standard 7 Performance, Even With 6" Deep Pans
- Standard Work Height 34-3/8" on 4" casters
- Environmentally Friendly, Non-Flammable R-450A Refrigerant
- Top Cut-Outs Accommodate Sixth Size Pans (divider bars and 4" deep plastic sixth size pans provided)
- Reinforced Pan Ledge (holds pans securely level)
- Removable Stainless Steel Insulated Pan Cover & Pivoting Lid
- Reversible, Full Length White Nylon Cutting Board
- Self-Closing Stainless Steel Doors with Stay-Open Feature at 105 Degrees
- Guaranteed for Life Workflow Door Handle
- Electronic Control
- Two (2) Powder Coated Steel Shelves Per Door, Mounted on Adjustable Pilasters
- Set of Six (6) 4" Casters
- Magnetic Snap-In EZ-Clean Door Gasket(s)
- 3-Year Parts & Labor Warranty
- 2-Year Additional Compressor Parts Warranty



This unit is listed to the applicable UL, CSA and NSF Standards by an approved NRTL. Consult the factory or unit's data plate for approval information.

AVAILABLE CONFIGURATIONS

27", 32", 48", 60" & 72" Wide Models

Model	Model Type
UPT7212	72" Wide 12 Pan Model
UPT7218	72" Wide 18 Pan Model
UPT7224	72" Wide 24 Pan Model
UPT7230	72" Wide 30 Pan Model

ACCESSORIES & OPTIONS (*field installed)

- CK21 (six 6" (15.2cm) high casters for 72" models)
- CK25 (six 3-1/2" (8.9cm) high casters for 72" models)
- CK27 (six 2-3/4" (6.9cm) high casters for 72" models)
- CUACC-LEGSET6 (six 6" (15.24 cm) high legs for 72" models)
- SHELF72 UPPER (upper shelf for 72" models)
- SHELF72 LOWER (lower shelf for 72" models)
- Optional accessory kits shipped separately for field installation

Factory Installed Options

- Stainless Steel Finished Back * Other Door Hinging

CONTINUED PRODUCT DEVELOPMENT MAY NECESSITATE SPECIFICATION CHANGES WITHOUT NOTICE.

Approved by _____ Date _____ Approved by _____ Date _____



MODELS:
UPT7212

CLICK
TRANSFER
For KCL CADalog Website

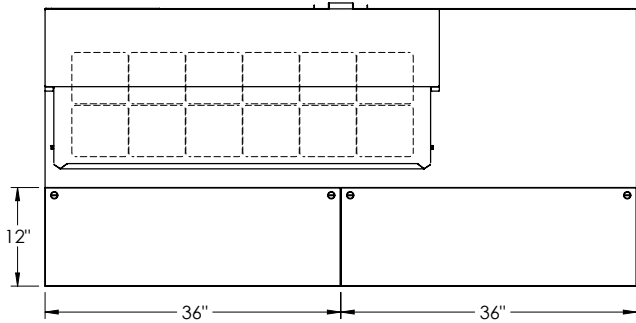

TOP VIEW

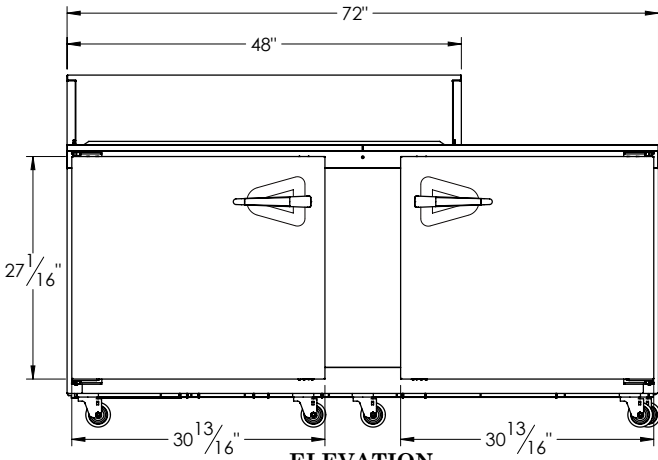
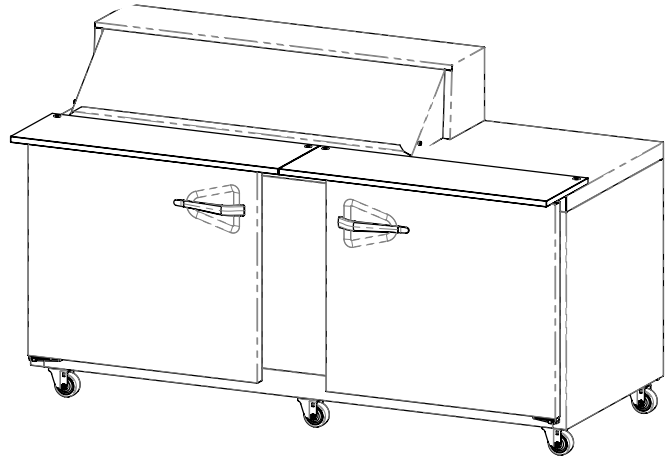

ELEVATION

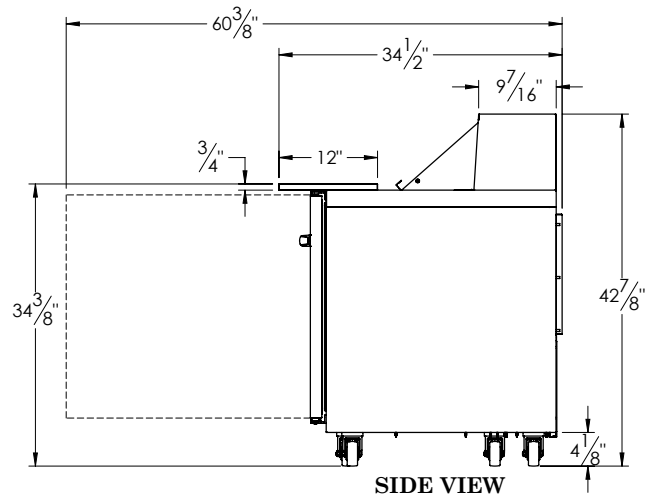

SIDE VIEW

COMPACT PREP TABLES

Self-Contained Solid Door(s)

MODELS:

UPT7230

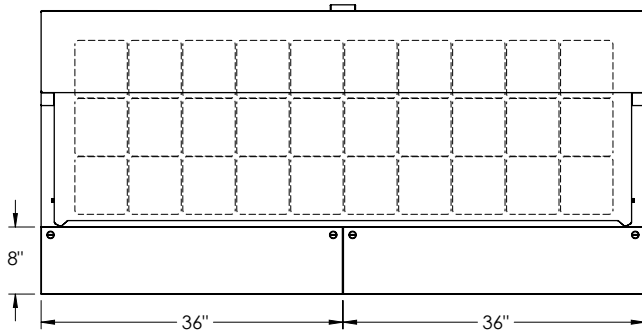

TOP VIEW

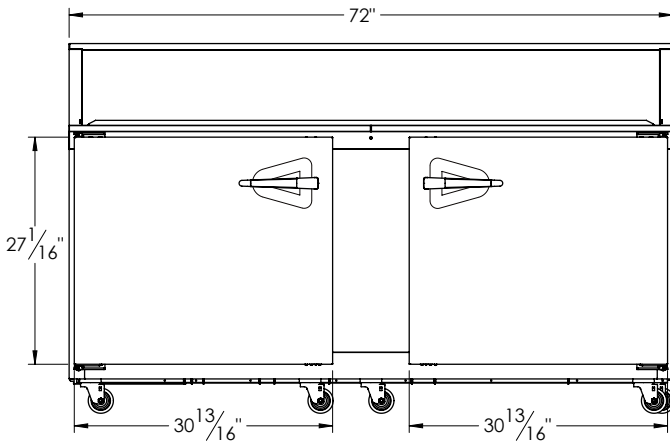
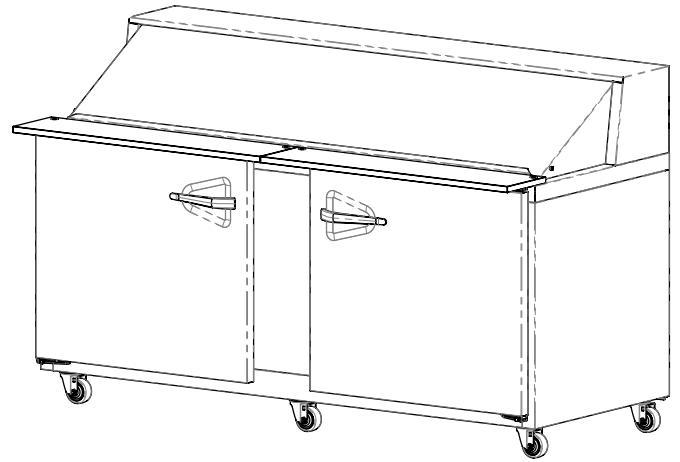

ELEVATION

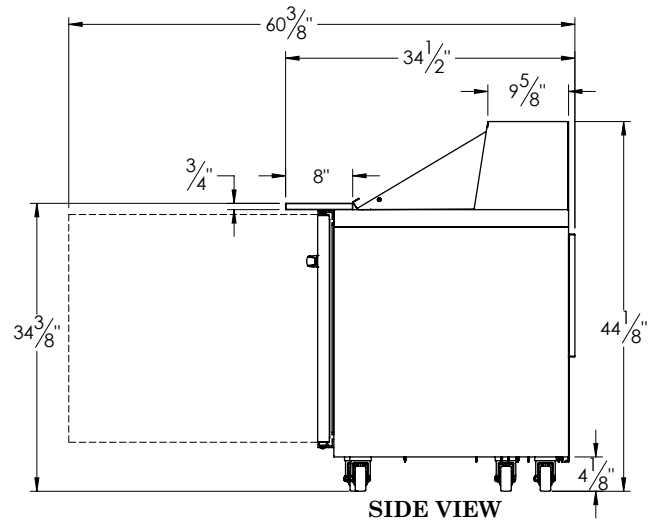

SIDE VIEW



UPT SERIES

Compact Sandwich Prep Tables with Raised Cover/Self -Contained

MODELS

Door Models: UPT7212, UPT7218, UPT7224, UPT7230

MODELS	UPT7212	UPT7218	UPT7224	UPT7230
CABINET DIMENSIONAL DATA				
Volume	N/A	N/A	N/A	N/A
# of 1/6 Size Pan Top	12	18	24	30
Width-Cabinet	72"	72"	72"	72"
Width-Door	29 5/8"	29 5/8"	29 5/8"	29 5/8"
Depth ¹ -door open 90°	60 3/8"	60 3/8"	60 3/8"	60 3/8"
Depth-Cutting Board	12"	8"	8"	8"
Depth-Lid Top	9 3/8"	9 5/8"	9 5/8"	9 5/8"
Width-Pan Cover Lid	48"	48"	60"	72"
Height-Overall (mounted on 4" casters)	42 3/4"	44"	44"	44"
Clear Door Opening	27 3/4"	27 3/4"	27 3/4"	27 3/4"
# of Doors	2	2	2	2
# of Shelves	4	4	4	4
Total Shelf area sq. ft	15.5	15.5	15.5	15.5
ELECTRICAL DATA & REFRIGERATION DATA 115/60/1 NEMA 5-15P				
Full Load Amps	7.5	7.5	7.5	7.5
MDEC ² (KWH)	N/A	N/A	N/A	N/A
Refrigerant	R-450A	R-450A	R-450A	R-450A
Refrigerant Amount oz. (gr)	12.5 (354)	12.5 (354)	12.5 (354)	12.5 (354)
BTU/HR ³ H.P.	1390 (1/4)	1390 (1/4)	1390 (1/4)	1390 (1/4)
SHIPPING DATA				
Width Crated in. (cm)	84 (213)	84 (213)	84 (213)	84 (213)
Volume Crated cu. ft. (l)	84 (2379)	84 (2379)	84 (2379)	84 (2379)
Weight lbs. (kg) - Crated	408 (185)	408 (185)	408 (185)	408 (185)

NOTES:

- Overall depth includes standard cutting board.
 - MDEC = Maximum Daily Energy Consumption
 - Based on a 90°F ambient and 20°F evaporator
- When ordering please specify: Voltage, Hinging, Optional Accessories and any additional warranties.
 - This unit may be manufactured in other electrical characteristics and may have additional regulatory agency approvals. Consult factory for other electrical characteristics and agency approvals based on specific electrical and country requirements.

EQUIPMENT SPECIFICATIONS

CONSTRUCTION, HARDWARE, INSULATION

Cabinet exterior front, sides, pan cover lid and doors are constructed of stainless steel. Cabinet interior and door liners are constructed of anodized aluminum. The exterior cabinet back at the bottom are constructed of galvanized steel.

Doors self close at less than 90 degrees and also includes a stay open feature at 105 degrees. Gasket profile and material simplify cleaning and increase overall gasket life.

Both the cabinet and doors are insulated with an average of 2" thick high density non-CFC, foamed in place polyurethane.

A 3/4" thick, full-length, reversible white nylon cutting board is supplied standard.

PANS & COVER

Each model is supplied standard with its full compliment of 4" deep plastic 1/6 size pans and stainless steel pan dividers. The lid is constructed of stainless steel, and is easily removable for cleaning.

REFRIGERATION SYSTEM

A balanced, rear mounted, front breathing, self-contained refrigeration system using environmentally friendly, non-flammable R-450A refrigerant is provided. It features a capillary tube metering device, air cooled hermetic compressor, a forced air evaporator coil and a non-electric condensate evaporator. An 8' cord and plug is provided. Standard operating temperature of the refrigerated base is 34° to 38°F (1.1° to 3.3°C).

CONTROLLER

An electronic digital control is supplied standard. It includes a 3-Digit LED display, and a Fahrenheit or Celsius temperature scale display capability.

INTERIOR

Standard interior arrangements include two (2) powder coated wire shelves per door, mounted on pilasters. These are adjustable in 1/2" (1.27 cm) increments, allowing for a minimum of 1-1/2" (3.81 cm) spacing between shelves.

WARRANTY

Both a three year parts and labor warranty and a five year compressor parts warranty (self-contained models) are provided standard.

CONTINUED PRODUCT DEVELOPMENT MAY NECESSITATE SPECIFICATION CHANGES WITHOUT NOTICE.