

Master Series Electric XPress Grill

Project _____
 Item _____
 Quantity _____
 CSI Section 11400
 Approved _____
 Date _____

Models

- XPE36
- XPE36CE
- XPE36-2L
- XPE36CE-2L



Model XPE36
Shown with flared grease cans

Standard Features

- Programmable control for each cooking lane precisely controls:
 - Automatic lifting and lowering of upper platen
 - Cooking gap and time
- EasyTouch™ screen design is simple and intuitive with Press and Go interface
- Advanced temperature control, smart anticipation versus on-off
 - Eliminates temperature overshoot and undershoot
 - Increases temperature uniformity with five independently controlled heat zones -- three on plate and two on platen
 - Each lane can be set to a different temperature for menu flexibility, eg., all-day breakfast
 - Each lane can be turned Off when not required -- saving energy
- Recipes are programmed by setting grill temperature, platen temperature, cooking gap up to 2 inches (5 cm) and cook time
- USB interface to update menus
- User interface provides advanced diagnostics and error logging for ease of service and increased first-time fix

- Stainless steel front, top and sides
- Towel bar with bun pan lip
- Stainless steel dual side grease collectors
- Swivel casters (4) with front brakes
- IPX4 water resistant rating
- Two-year limited parts and labor (USA & Canada)
- Available with 2 upper platen only on either side the left or the right:
 - 2L or -2R

Options & Accessories

- Grease cans are available with
 - straight sides for minimum space
 - flared sides to hold optional tool holders
- Optional tool holders
 - 4-inch spatula
 - 6-inch scrapper
 - 7-inch wiper

Specifications

The XPress Grill's upper and lower grill plates cook both sides simultaneously, reducing cook times by up to 50%. Upper grill plate is automatically raised and lowered by a lift system powered by a quiet actuator.

Lower griddle plate made of 3/4" (19mm) thick carbon steel, machine ground and highly polished.

Lower grill plate heated by three electric heating elements.

Upper platen heated by nickel plated cast aluminum electric heating elements.

Electric top heater provided with replaceable quick release Teflon sheets. Available in three phase power for Delta or Wye electrical systems.

Voltage sensing and power management automatically adjusts power to electrical system voltage.

Available with CSA or CE approvals. All have NSF approval.

Installation with zero clearance against non-combustible surfaces.



Master Series Electric XPress Grill

Master Series Electric XPress Grill

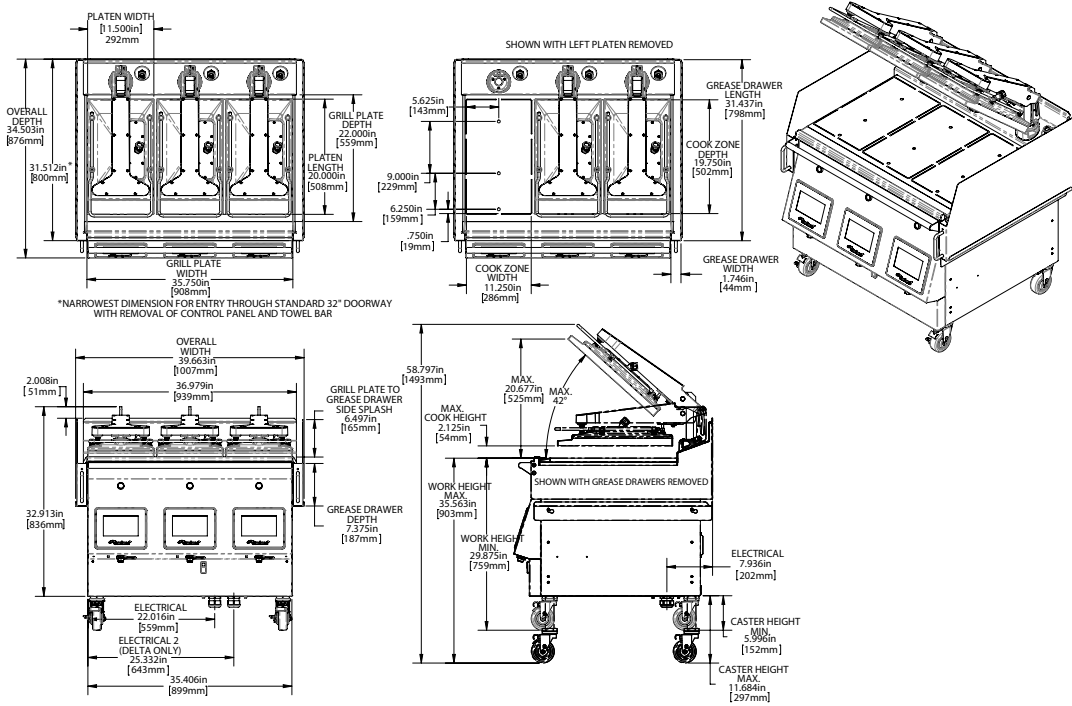

Electrical Input Specification -DELTA					
XPE36 CSA Models - Delta					
Model	Volts 3 Ph 50/60 Hz	Total Current (A)			Power (kW)
		L1	L2	L3	
3 Platen Cord 1	200V	25.8	23.6	26.5	16.0
	208V	25.6	23.3	26.2	16.2
	220V	23.7	22.0	24.1	15.8
	230V	22.6	21.2	23.5	15.9
	240V	22.5	21.0	23.4	15.9
3 Platen Cord 2	200V	49.4	51.6	48.7	8.0
	208V	48.4	50.8	48.1	8.1
	220V	44.6	46.8	45.1	7.9
	230V	42.8	44.9	43.9	7.9
	240V	42.3	44.5	43.0	7.9
XPE36-2L & XPE36-2R CSA Models - Delta					
Model	Volts 3 Ph 50/60 Hz	Total Current (A)			Power (kW)
		L1	L2	L3	
2 Platen Cord 1	200V	13.9	16.8	25.8	5.3
	208V	14.0	16.5	25.6	5.4
	220V	13.8	15.2	24.1	5.2
	230V	13.8	14.6	23.5	5.3
	240V	13.8	14.6	23.4	5.3
2 Platen Cord 2	200V	51.6	48.7	49.4	16.0
	208V	50.8	48.1	48.4	16.2
	220V	46.8	45.1	44.6	15.8
	230V	44.9	43.9	42.8	15.9
	240V	44.5	43.0	42.3	15.9

Electrical Input Specification - WYE					
XPE36 CE Models - WYE					
Model	Volts 3 Ph 50/60 Hz	Total Current (A)			Power (kW)
		L1	L2	L3	
3 Platen	220V/380V	39.3	39.3	39.3	23.6
	230V/400V	37.2	37.2	37.2	23.8
	240V/415V	37.2	37.2	37.2	23.8
XPE24-1L & XPE24-1R CE Models - WYE					
Model	Volts 3 Ph 50/60 Hz	Total Current (A)			Power (kW)
		L1	L2	L3	
2 Platen	220V/380V	39.3	27.3	39.3	21.0
	230V/400V	37.2	26.4	37.2	21.2
	240V/415V	37.2	26.4	37.2	21.1

Welbilt reserves the right to make changes to the design or specifications without prior notice.