

Coolscapes® Reach-In Refrigerator

Project _____
Item _____
Quantity _____
CSI Section 11400
Approved _____
Date _____

Models

- GBR1P-S
- GBR2P-S
- GBR3P-S
- GBR1P-SH
- GBR2P-SH
- GBR3P-SH



GBR1P-SH

Standard Features

- GreenGenius™ R290 top mount refrigeration system featuring TXV expansion valve and hot gas condensate removal
- Digital exterior temperature display with high/low temp visual alarms
- Energy saving LED interior light
- Removable side louver
- Accommodates full size sheet pans
- Raised ABS interior door liner
- Gray epoxy coated shelves (3 per section) with shelf bridge
- Smart door hinge that auto closes up to 90° and stays open past 90°
- Integral door handle
- 180° door opening
- Energy efficient door gasket – removable without tools
- Locking doors
- 5" locking casters shipped loose for field installation
- 10' cord and plug attached
- Stainless steel exterior front
- Stainless steel exterior sides
- Gray coated aluminum interior
- Stainless steel interior floor
- Field rehingable doors - full height doors only
- Stainless steel pilaster with shelf clips
- Vapor lock relief valve
- Three year parts and labor warranty and an additional two year compressor parts warranty

Options

- GC Series feature set (includes pins, aluminum interior/exterior, no PRV)
- GBS Series feature set (stainless steel interior in lieu of standard aluminum interior)

Specifications

Refrigeration system: All components are mounted to the top cabinet ceiling, outside the food zone and are assembled as one piece and can be removed as one piece. Environmentally friendly R290 refrigerant is used. System has the capability of maintaining between 33°F and 40°F in heavy use food service operations. Refrigerant is metered using a highly responsive thermostatic expansion valve. System is controlled using an electronic temperature control, which provides improved pull down times, reducing compressor cycling and longer compressor life with

lower energy consumption. Control system uses adaptive defrost to assure evaporator coil is free of ice and operating at optimum efficiency. Evaporator condensate is eliminated using an energy efficient hot gas system.

Units are completely insulated with high density foamed in place environmentally friendly, Kyoto Protocol Compliant, Non ODP (Ozone Depletion Potential), Non GWP (Global Warming Potential) polyurethane.



Coolscapes® Reach-In Refrigerator

Coolscapes® Reach-In Refrigerator

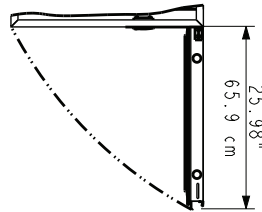
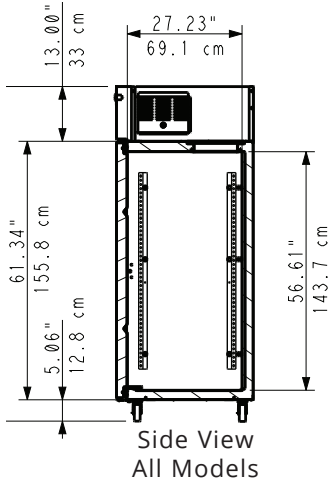
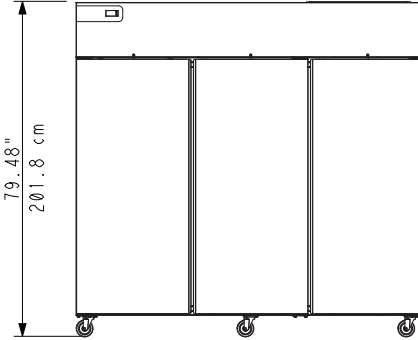
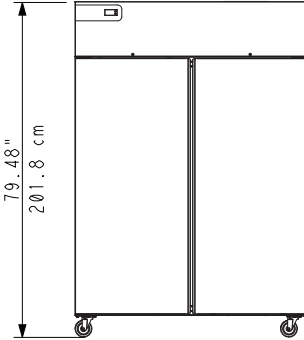
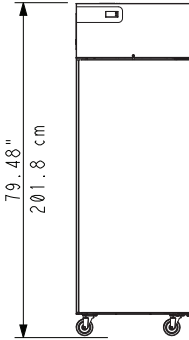
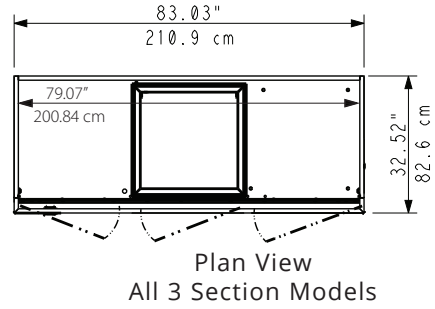
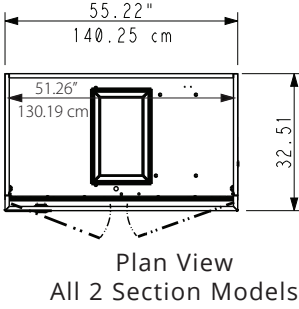
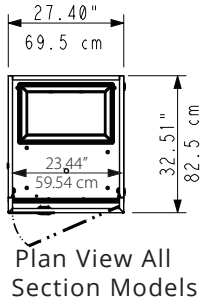

- Available with full or half stainless steel doors.
- Available with aluminum or stainless steel exterior sides.

Energy star® rated models	
Model	Energy kWh
GBR1P-S	1.65
GBR1P-SH	1.70
GBR2P-S	2.71
GBR2P-SH	2.49
GB, R3P-S	3.59
GBR3P-SH	3.54

Specifications								
Description	Model	V/Hz/ph	Amps	# of Shelves	Volume	H.P.	Nema Plug	Ship Weight
1-section Refrigerator	GBR1P-S(H)	115/60/1	4.2	3	21ft3/595L	.22	5-15P	312lbs/142kg
2-section Refrigerator	GBR2P-S(H)	115/60/1	6.0	6	46ft3/1303L	.33	5-15P	495lbs/225kg
3-section Refrigerator	GBR3P-S(H)	115/60/1	6.5	9	71ft3/2010L	.355	5-15P	727lbs/330kg

Welbilt reserves the right to make changes to the design or specifications without prior notice.