

PROJECT:	
MODEL #:	
ITEM #:	QTY:
AVAILABLE W/H:	APPROVAL:

## One Compartment Sinks



BS1-18-12/L



BS1-18-12/2D



BS1-18-12/R



BSP-18

### STANDARD FEATURES

- Entire ASSEMBLY is fused Welded, shielded and polished to create a one piece seamless sink Unit
- Welded areas are high-speed belt blended to match adjacent surfaces with the continuity of a satin finish
- Swirl away bowl drainage
- Adjustable ABS bullet feet
- All sink compartments are covered With a full 5/8" radius
- Stainless Steel cross braced legs and gussets for additional strength and stability
- All Sink Models Equipped with standard strainers with Brass Fittings instead of Aluminum
- Die-stamped creased drain boards for positive drainage



Conforms to NSF/ANSI 2

WARRANTY

APPROVALS:

AVAILABLE AT:

# One Compartment Sinks

## PRODUCT PLAN VIEW

- Top View -

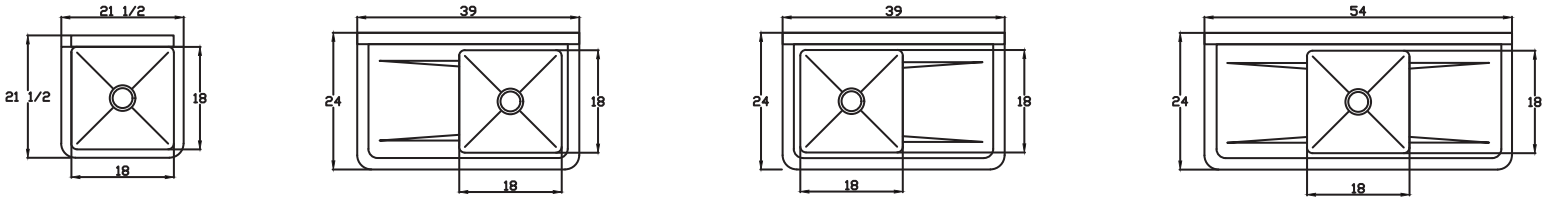

- Front View -

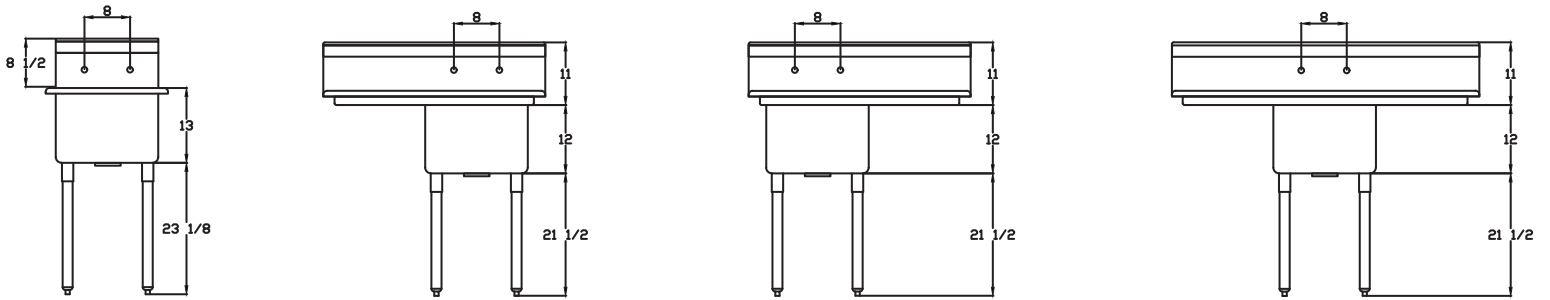

**BSP-18**

**BS1-18-12/L**

**BS1-18-12/R**

**BS1-18-12/2D**

- Side View -

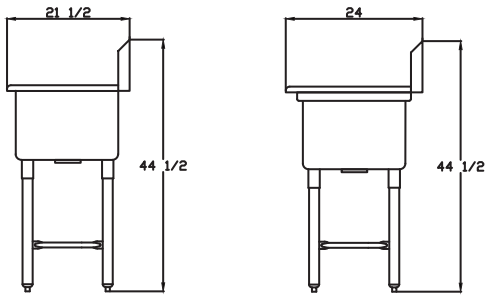

**BSP-18**

**BS1-18-12/L**  
**BS1-18-12/R**  
**BS1-18-12/2D**

## PRODUCT SPECIFICATION

### One Compartment Sinks

Model	Description	Overall Size (inches / mm)			Bowl Size (inches / mm)			Net Weight (lbs/kg)	Ship Weight (lbs/kg)
		L	D	H	L	D	H		
BSP-18	1 Compartment (Prep Sink)	21 1/2"(546mm)	21 1/2"(546mm)	44 1/2"(1130mm)	18"(458mm)	18"(458mm)	13"(330mm)	31(14)	34(15)
BS1-18-12/L	1 Compartment 1 Left Drain Board	39"(991mm)	24"(610mm)	44 1/2"(1130mm)	18"(458mm)	18"(458mm)	12"(305mm)	42(19)	46(21)
BS1-18-12/R	1 Compartment 1 Right Drain Board	39"(991mm)	24"(610mm)	44 1/2"(1130mm)	18"(458mm)	18"(458mm)	12"(305mm)	42(19)	46(21)
BS1-18-12/2D	1 Compartment 2 Drain Boards	54"(1372mm)	24"(610mm)	44 1/2"(1130mm)	18"(458mm)	18"(458mm)	12"(305mm)	50(23)	55(25)

\*BLUE AIR has the right to change specifications without further notice.

**Blueair**  
FOOD SERVICE EQUIPMENT LLC

www.blueairfse.com  
info@blueairfse.com  
**1.886.677.8500**

223 W. Rosecrans Ave., CA 90248  
T: 310.808.0102 F: 310.808.0242  
9 W. Shelton Terrace #A, Hillside, NJ 07205  
T: 310.808.0102 F: 310.808.0242