

Project Name: _____
 Location: _____
 Item #: _____ Qty: _____
 Model: _____

SANDWICH / SALAD STATIONS

MODEL: MXSR29SHC MXSR48SHC MXSR60SHC



MXSR29SHC



MXSR48SHC



MXSR60SHC

Maxx Cold Select Series Sandwich Stations provide the perfect blend of durability and accessibility to allow for quicker and easier preparation of sandwiches, salads and more at a value price. Hinged food covers keep the food well contents fresh and cool throughout the day. A high quality stainless steel exterior allows for easy cleaning. If properly maintained, this appliance will provide years of reliable, cost effective performance.

FEATURES AND CONSTRUCTION

- Exterior Material: Durable, easy to clean stainless steel
- Interior Material: Easy to clean painted aluminum
- Environmentally friendly, CFC-free urethane foam insulated walls and doors
- Heavy duty epoxy coated shelves for easy access and minimal maintenance without disrupting air flow
- Open well is designed to hold 1/3, 1/2 or full size pans without requiring adapters
- Open well includes slots for industry standard adapter bars to allow use of 1/6 pans
- Comes equipped with removable reversible cutting board
- Comes equipped with 4 (MXSR29SHC), 6 (MXSR48SHC) or 8 (MXSR60SHC) pans (1/3 size)
- Rear-accessed utility compartment provides space efficiency as well as easier servicing while conserving energy consumption
- Easily replaceable dart-style magnetic compression gaskets
- Easy to grip, stainless steel, self-closing doors with integrated door handles
- Four (4) 5.5" casters (2 locking) for mobility
- Adjustable wire shelves (one per section/door)
- Integrated condensate evaporator pan eliminates the need for a floor drain connection

ELECTRIC

115V / 60Hz / 1Ph
 (230V / 50-60Hz / 1Ph is available as an option)
 6' (2m) NEMA 5-15P cord set included

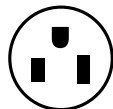

NEMA 5-15P

3RD PARTY APPROVALS



Intertek

Certified to ANSI NSF 7



Intertek

Certified to ANSI UL 471



DOE 2017 Compliant

MAXX COLD WARRANTY (USA / CANADA)

Contact Maxx Cold for warranty statement at
 TechnicalServices@TheLegacyCompanies.com or 877.368.2797

TEMPERATURE

Holding temperature 33°F to 41°F (1°C to 5°C)

- Efficient, forced-air refrigeration system delivers even temperature regulation throughout the storage compartment
- Easily adjustable solid state control scheme with digital temperature display
- Oversized refrigeration and efficient foam insulation provides rapid recovery and excellent temperature regulation

MXSR29SHC

MXSR48SHC

MXSR60SHC

FRONT VIEW

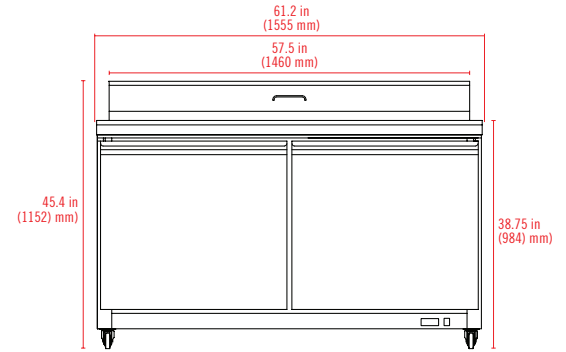
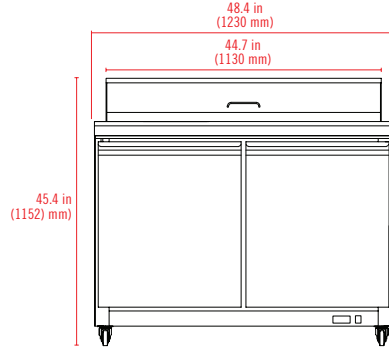
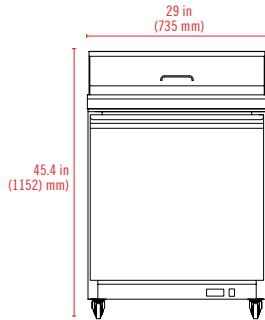

TOP VIEW

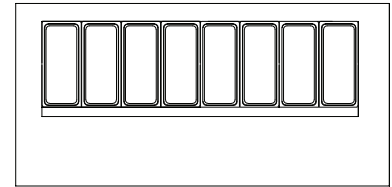
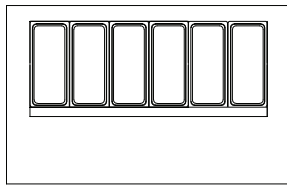
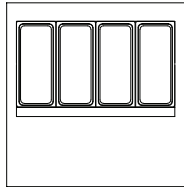

SIDE VIEW
(ALL MODELS)

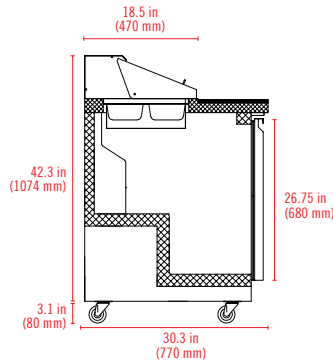

MODEL	EXTERNAL DIMENSIONS	INTERNAL DIMENSIONS	NET CAPACITY	HOLDING TEMPERATURE RANGE	AMP DRAW	UNIT WEIGHT	REFRIGERANT	PAN CAPACITY 1/3 (1/6)	DOORS / SHELVES	ELECTRICAL
MXSR29SHC	29" x 30.3" x 45.4" (735 x 770 x 1152 mm)	24" x 23.4" x 26.6" (610 x 636 x 676 mm)	7.59 Cu Ft (215 L)	33°F to 41°F (1°C to 5°C)	3.6A	150 lbs (68 kg)	R-290a	4 (8)	1 / 1	115V / 60Hz / 1Ph
MXSR48SHC	48" x 30.3" x 45.4" (1230 x 770 x 1152 mm)	43" x 23.4" x 26.6" (1105 x 636 x 676 mm)	13.8 Cu Ft (390 L)	33°F to 41°F (1°C to 5°C)	4.3A	256 lbs (116 kg)	R-290a	6 (12)	2 / 2	115V / 60Hz / 1Ph
MXSR60SHC	61" x 30.3" x 45.4" (1555 x 770 x 1152 mm)	56" x 23.4" x 26.6" (1430 x 636 x 676 mm)	17.8 Cu Ft (505 L)	33°F to 41°F (1°C to 5°C)	5.6A	298 lbs (135 kg)	R-290a	8 (16)	2 / 2	115V / 60Hz / 1Ph

INSTALLATION

- Shorter caster options are available to lower the overall height of the unit