



Model: KR-LC2GF-TT Item #: Date:
 Project: Qty: Approved By:

Table Top Liquid CO2 Glass Froster

Royal Series Underbar



SPECIFICATIONS

Outside Dimensions	7-7/8" x 7-7/8" x 6-11/16"
Unit Weight	12.8 lb approx. with battery 9.5 lb approx. without battery (excludes CO2 cylinder)
Gas Refrigerant	CO2 (food grade) Carbon Dioxide
Cylinder Type	CO2 Cylinder with Siphon tube (not included)
CO2 Line Length	Approx 10 ft. (including connection valve) - KR-LC2GF-TT Approx 40 ft. (including connection valve) - KR-LC2GF-TT-E
Power Supply	Rechargeable 12V battery - 100/240 V AC Plug
Power Input	100 - 240 V AC
Frequency	50 - 60 Hz
Max Power Capacity	50W
Included Accessories	Includes worktop mounting kit & battery charger

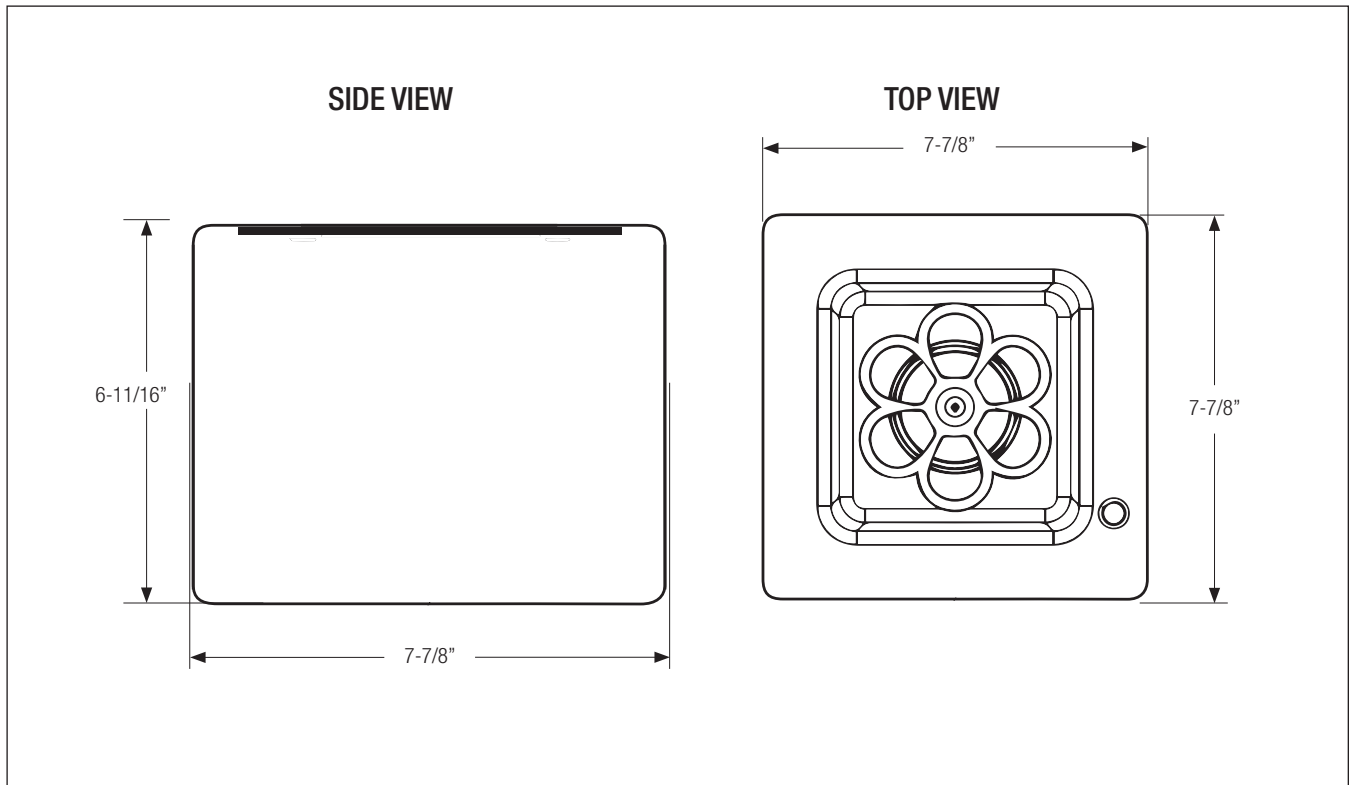

⚠ Warning: This product can expose you to chemicals including lead and lead compounds which are known to the State of California to cause cancer and birth defects or other reproductive harm. For more information go to www.P65Warnings.ca.gov.