



# BEVERAGE-AIR

Project: \_\_\_\_\_

AIA#

Item: \_\_\_\_\_

Location: \_\_\_\_\_

SIS#

Approved: \_\_\_\_\_

## DD Draft Beer Equipment-Direct Draw Dispenser

DD58HCC Solid Door Club Top

Hydrocarbon Series

**MODELS:**

**DD58HC-1-C-B**

**DD58HC-1-C-S**



**DD58HC-1-C-B**



**DD58HC-1-C-S**

**3 Year Parts/Labor Warranty**  
**Additional 2 Year Compressor Warranty**

### CABINET CONSTRUCTION

- Exterior black or stainless steel front and door, gray painted sides
- Top and drip tray are heavy-duty stainless steel
- Interior is galvanized steel on walls and ceiling, reinforced floor and doorsills are heavy duty stainless steel
- Club top, easy glide stainless steel lid for additional storage of glasses, cans or bottles, includes (1) epoxy coated shelf and (1) basket
- Full electronic control
- Two (2) single faucets standard
- 3-in-1 Draft Solution uses a single stainless-steel tap to serve different beverages, such as wine, beer, and coffee (or other non-alcoholic beverages) through silver-lined, anti-microbial tubing that is 100% effective against the top 4 beverage spoiling bacteria
- 3" Stainless steel insulated dispensing tower
- Drain tube located at bottom front of cooler for connection to floor drain
- Self-closing doors with locks
- Magnetic gaskets provide positive door seal
- Compressor available on left or right, specify at time of unit order
- Maintains product temperatures between 36°F and 38°F

### OPTIONS & ACCESSORIES

- Full stainless steel exterior
- Stainless steel interior lining
- Custom tower hole location
- Drip tray location option
- Wine models
- Faucet locks
- 3" Casters or 6" black legs
- 1-6 Tap tower
- 2, 3 & 4 way manifolds
- No draft arm/ hole cover
- Remote option  
(Refrigerant must be specified at time of order, see note on back on page)

### REFRIGERATION SYSTEM

- Refrigeration system uses R290 refrigerant to comply with all environmental concerns
- Automatic, non-electric defrost
- Epoxy coated evaporator coil

DD58HCC Direct Draw Dispenser: Club Top



3779 Champion Blvd., Winston-Salem, NC 27105  
1-888-845-9800 Fax: 1-336-245-6453  
Beverage-Air.com sales@bevair.com



# BEVERAGE-AIR

## Beer Equipment– Direct Draw Dispenser Solid Door Club Top

Models: DD58HC-1-C-B, DD58HC-1-C-S

MODEL	DD58HC-1-C-B	DD58HC-1-C-S
<b>EXTERNAL DIMENSIONAL DATA</b>		
Width Overall	59"	59"
Depth Overall with Handle	29"	29"
Height Overall	52 1/2"	52 1/2"
Number of Doors	2	2
Depth with Door Open 90°	52 1/2"	52 1/2"
Door Opening (inches)	21" x 30"	21" x 30"
<b>INTERNAL DIMENSIONAL DATA</b>		
NET Capacity (cubic ft.)	21.86	21.86
Internal Width Overall (in)	46 1/8"	46 1/8"
Internal Depth Overall (in)	23 1/8"	23 1/8"
Internal Height Overall—(in)	27 3/8"	27 3/8"
Number of 1/2 Kegs	3	3
<b>ELECTRICAL DATA</b>		
Full Load Amperes* 115/60/1	2.5	2.5
<b>REFRIGERATION DATA</b>		
Horsepower*	1/4	1/4
Capacity (BTU/Hr)*	1702	1702
<b>WEIGHT DATA</b>		
Gross Weight (Crated lbs)	342 lbs	342 lbs
Height - Crated	41 1/4"	41 1/4"
Width - Crated	62"	62"
Depth - Crated	31 1/4"	31 1/4"

\*NOTE: Remote units are field wired and comes with 6" legs. Refrigerant must be specified at time of order.

DD58/68/72 KEG CAPACITY:

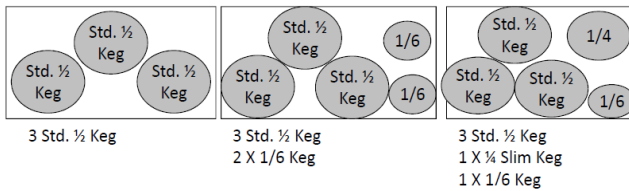

### Model Views

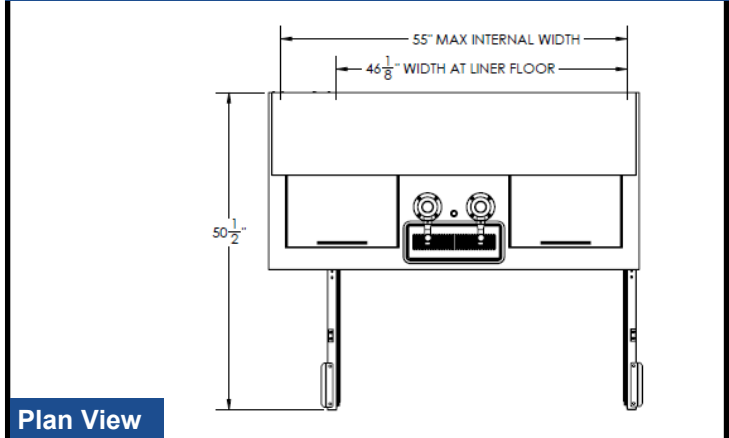

Plan View

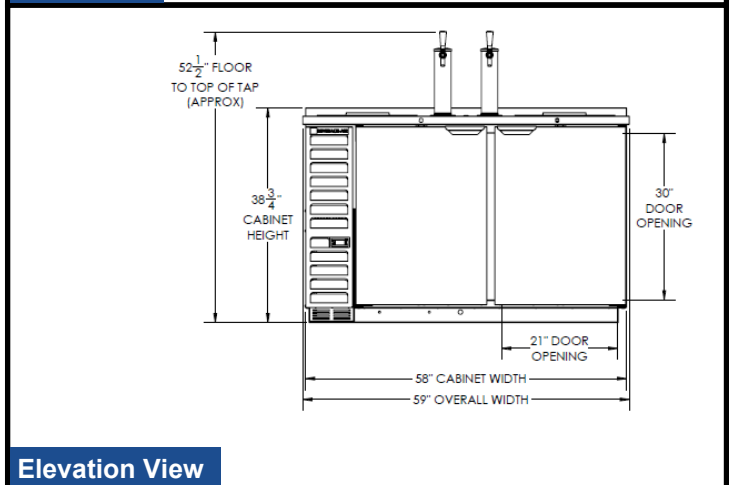

Elevation View

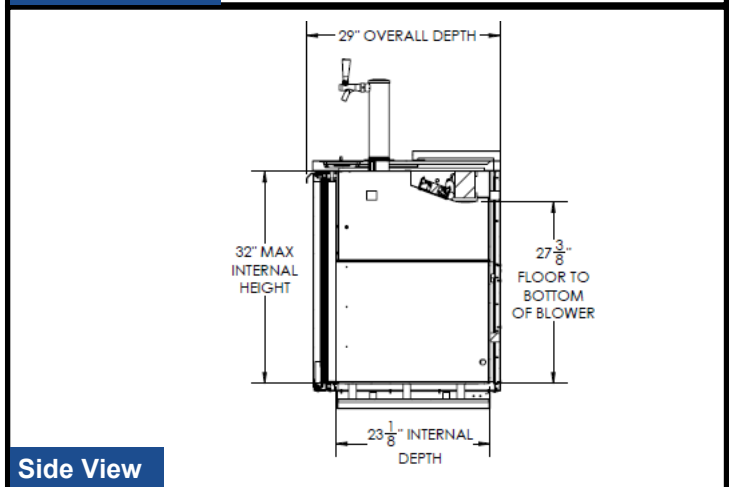

Side View

### \*ELECTRICAL CONNECTION



115/60/1  
NEMA-5-15P

Units pre-wired at factory and include 8' long cord and plug set.



an Ali Group Company



The Spirit of Excellence

3779 Champion Blvd., Winston-Salem, NC 27105  
1-888-845-9800 Fax: 1-336-245-6453  
Beverage-Air.com sales@bevair.com