



CMA-180T

High Temperature
Pot & Pan Single Rack
Split Door Dishwasher

**NEW
SPLIT DOOR
FEATURE**



Corner Model



Straight Model

FEATURES:

- **Energy Star® Approved**
- 60 racks / 240 covers per hour.
- Economical to operate. Uses only 1.24 gallons of water per cycle.
- Split-door design provides a sheet pan door clearance of 27-inches, reduces overall (open-door) height of machine to 93-1/2". A beneficial feature for kitchens with low ceilings.
- Automatic soil purging system filters wash water and traps plate debris into an external tray. Tray can be easily removed for dumping contents.
- All stainless steel construction offers durable performance and years of trouble free operation.
- Built-in chemical resistant industrial 7kW heater is proven to be more durable than commercial style heaters.
- Unique spray arm system features upper and lower stainless steel wash arms with reinforced end caps. Specially designed pull-pins allow wash arms to be easily removed for cleaning.
- Top mounted control box is water tight and includes a rack counter, extended wash/delimer switch and easy to read temperature gauges.
- Auto start/stop makes operation safe and easy.
- Field convertible for a wide range of applications.
- Safety Temp feature assures 180°F sanitizing rinse every cycle.
- Single point electrical connection.
- Automatic tank fill.
- Interchangeable upper and lower arms.

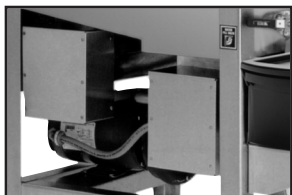

Industrial wash tank and optional booster heaters are designed for years of trouble free service.

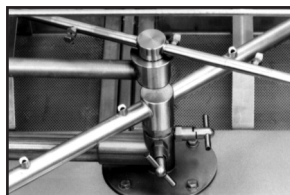

Unique pull-pin design allows wash arms to be easily removed for cleaning.



Top mounted control box is water tight and includes a rack counter, extended wash/delimer switch and easy to read temperature gauges.

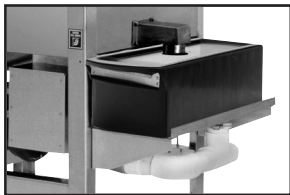

External scrap tray maintains clean wash water and prevents debris from clogging the drain.



Large 27" door opening accommodates larger items.

Available Options:

- Exhaust Fan Time Control
- Built-in 12kW booster heater
- CMA-180 Conversion Kit Corner to Straight PN: 617.29
- CMA-180 Conversion Kit Straight to Corner PN: 617.39
- Alternative electrical available for export
- Dual power supply connections
- Stainless steel dishtables
- 2 minute cycle
- Stainless steel scrap trap

**CMA
MIZER®**
Registered Trademark





CMA-180T

High Temperature
Pot & Pan Single Rack
Split Door Dishwasher

WARNING: Plumbing connections must be made by a qualified service company who will comply with all available Federal, State, and Local Health, Plumbing and Safety codes.

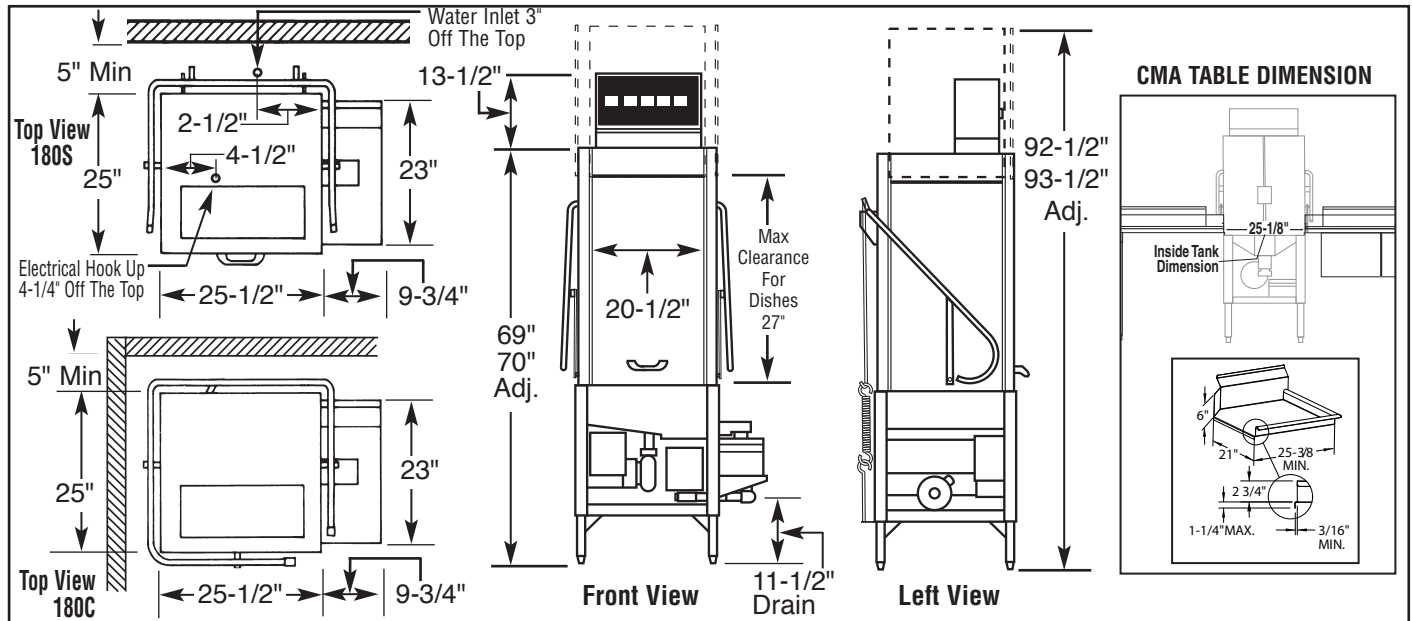

Specifications:

MODEL CMA-180T SPLIT DOOR	USA	METRIC	USA	METRIC
WATER CONSUMPTION				
PER RACK	1.24 GAL.	(4.65 L)		
PER HOUR	74.4 GPH	(281.2 L)		
OPERATING CYCLE				
WASH TIME - SEC.	44	44		
RINSE TIME - SEC.	11	11		
TOTAL CYCLE	55	55		
OPERATING CAPACITY				
RACKS PER HOUR	60	60		
WASH TANK CAPACITY	8 GAL.	(30.3 L)		
PUMP CAPACITY	68 GPM	(257 LPM)		
WATER REQUIREMENTS				
WITHOUT BOOSTER HEATER	180°F	(82°C)		
WITH BOOSTER HEATER	120°F -140°F	(49°C - 60°C)		
WATER INLET	3/4"	(1.9 cm)		
DRAIN CONNECTION	2"	(5.1 cm)		
RINSE PRESSURE SET	20 ±5psi	(1.41 kg/cm ²)		
OPERATING TEMPERATURE				
WASH-°F (MIN)	155°F-160°F	(68°C-71°C)		
RINSE-°F (MIN)	180°F-195°F	(82°C-90°C)		
WASH PUMP MOTOR HP	1	1		
FRAME DIMENSIONS				
DEPTH	25"	(63.5cm)		
WIDTH (OUTSIDE DIMISION)	25-1/2"	(65cm)		
HEIGHT	69"-70"	(175-178cm)		
STANDARD TABLE HEIGHT	34"	(86.3cm)		
MAX CLEARANCE FOR DISHES	27"	(68.6cm)		
DRAIN CONNECTION (OFF FLOOR)	11-1/2"-12-1/2"	(29-32cm)		
STANDARD DISHRACK DIMENSIONS	1 19-3/4" X 19-3/4"	1 (50X50cm)		
ELECTRICAL RATING	VOLTS	PHASE	AMPS	
WITHOUT BOOSTER	208	1	36	
	240	1	38	
	208	3	24	
	240	3	26	
	480	3	10	
	WITH BOOSTER	208	1	78
240		1	88	
208		3	49	
240		3	55	
480		3	25	
SHIPPING WEIGHT				
WITHOUT BOOSTER	353#		(160kg)	
WITH BOOSTER	396#		(180kg)	

Summary Specifications: Model CMA-180T Split Door

The model CMA-180T Split Door single tank, high temperature dishwasher is designed for years of trouble free service, producing sparkling results while conserving energy, water and chemicals. This machine is available with an optional "built in" booster heater, assuring a continuous supply of 180°F hot water, and can accommodate dishes and utensils up to 27" high. Constructed entirely of stainless steel. Unique soil purging system filters wash water and plate debris into an external tray. The CMA-180T Split Door meets NSF, UL, CUL and CE standards.

Available Models

- CMA-180TS Tall Straight Split Door
- CMA-180TSB Tall Straight Split Door with booster
- CMA-180TC Tall Corner Split Door
- CMA-180TCB Tall Corner Split Door with booster



CMA Dishmachines 12700 Knott Street Garden Grove, CA 92841 • 800-854-6417 • 714-898-8781 • Fax: 714-895-2141 • www.cmadishmachines.com

CMA reserves the right to modify specifications or discontinue models without prior notification.