



# ELEVATION SERIES CUBE ICE MAKER

## CIM1446/1447



CIM1446 ON B110

### Features

- Space-saving 26.8" (681 mm) tall design.
- Produces up to 1,560 lbs (771 kg) of ice per day.
- *Harvest Assist* provides consistent ice production for the life of the ice maker while reducing energy consumption and increasing capacity.
- *Pure Ice*® exclusively by Ice-O-Matic. Built-in antimicrobial protection for the life of the ice maker inhibits bacteria growth on ice maker surfaces. Ice-O-Matic's optional water filtration system provides protection against unpleasant tastes, odors and scale formation.
- Durable, electroless nickel plating on all evaporator plates ensures reliability.
- *Longest warranty in the industry.* Purchase an Ice-O-Matic water filter with your cube ice maker, replace the filter every six months, and the evaporator warranty is extended to 7 years parts and labor (available in the U.S. and Canada only).
- Constructed from corrosion-resistant stainless steel and fingerprint-proof plastic.

CIM1446/1447 CUBE ICE MAKER

### Options & Accessories

WATER FILTERS		
Ice Machine Model	Manifold	
	System	Replacement
CIM1446	IFQ2-XL	IOMQXL (2)
CIM1447		

### Ice Maker Warranty

Every Ice-O-Matic ice maker is backed by a warranty that provides both parts and labor coverage.

- Three years **Parts and Labor**.
- Five years **Parts** coverage on the evaporator and compressor.
- Seven years **Parts and Labor** on the evaporator when you purchase an Ice-O-Matic water filter with your cube ice maker and replace the filter every six months (available in the U.S. and Canada only).

### Ice Form



#### CUBE

FULL CUBE DIMENSIONS	
W x D x H (in.)	7 <sup>7</sup> / <sub>8</sub> x 7 <sup>7</sup> / <sub>8</sub> x 7 <sup>7</sup> / <sub>8</sub>
W x D x H (mm)	22 x 22 x 22
HALF CUBE DIMENSIONS	
W x D x H (in.)	3 <sup>7</sup> / <sub>8</sub> x 7 <sup>7</sup> / <sub>8</sub> x 7 <sup>7</sup> / <sub>8</sub>
W x D x H (mm)	10 x 22 x 22

### Bin Chart *Kits for Combining Wider Bins with Smaller Models*

ICE STORAGE BINS											
Kits	Model No.	B25	B40	B42	B55	B700	B1000	B110	B1300	B1325	B1600
	Capacity Width	242 lbs (110 kg) 30 in (762 mm)	344 lbs (156 kg) 30 in (762 mm)	351 lbs (160 kg) 22 in (559 mm)	510 lbs (232 kg) 30 in (762 mm)	680 lbs (308 kg) 30 in (762 mm)	1000 lbs (454 kg) 48 in (1,219 mm)	854 lbs (388 kg) 48 in (1,219 mm)	1320 lbs (599 kg) 48 in (1,219 mm)	1325 lbs (601 kg) 60 in (1,524 mm)	1660 lbs (753 kg) 60 in (1,524 mm)
CIM1446	N/A						Kit Not Required	Kit Not Required			
CIM1447	N/A						Kit Not Required	Kit Not Required			

See Ice-O-Matic Price List for Adapter Kits to combine ice makers with most available ice/beverage dispensers.



# ELEVATION SERIES CUBE ICE MAKER CIM1446/1447



CIM1446/1447 CUBE ICE MAKER

## Air Cooled

Please note: air-cooled units require 6" (152 mm) clearance for air intake and exhaust.

- A. Ice maker potable water in, 3/8" FPT.
- B. Ice maker water out, 3/4" FPT.
- C. Hole for electrical connections, 7/8".
- D. Electrical junction box.

Dual Exhaust for Installation Flexibility

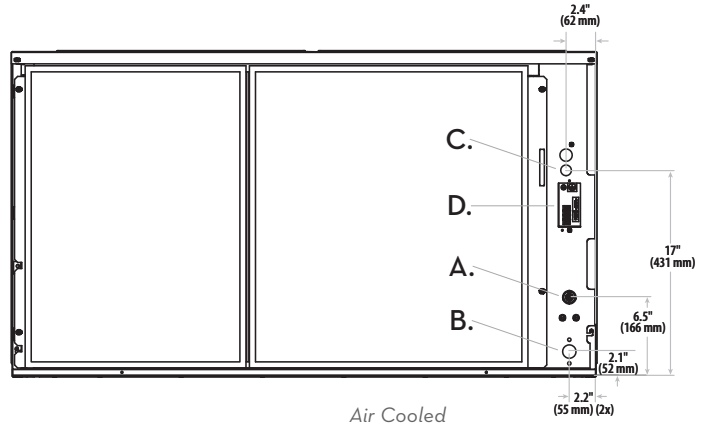
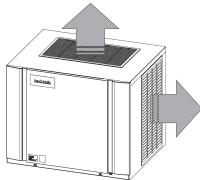

Air Cooled

## Water Cooled/Remote

- A. Ice maker potable water in, 3/8" FPT.
- B. Ice maker water out, 3/4" FPT.
- C. Hole for electrical connections, 7/8".
- D. Electrical junction box.
- E. Condenser water in, 3/8" FPT (water only).
- F. Condenser water out, 1/2" FPT (water only).
- G. Liquid line, 3/8" male quick connect coupling for precharged line set (remote only).
- H. Discharge line, 1/2" male quick connect coupling for precharged line set (remote only).
- I. Hole for remote electrical connections, 7/8" (remote only).

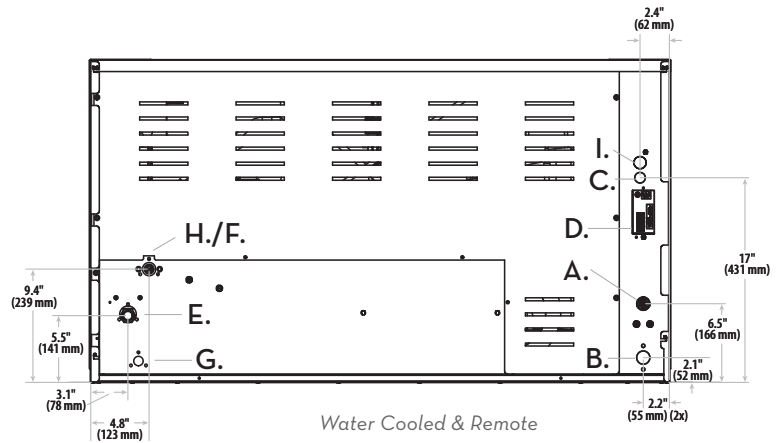

Water Cooled & Remote

## Operating Requirements

	MINIMUM	MAXIMUM	
		60 Hz	50Hz
Ambient Temp. Range Air	50°F (10°C)	100°F (38°C)	110°F (43°C)
Water Temp.	40°F (4.4°C)		
Water Pressure	20 PSIG (1.4 BAR)	60 PSIG (4.1 BAR)	

## Dimensions

ALL MODELS	
W x D x H (in.)	48.25 x 24.25 x 26.8
W x D x H (mm)	1,226 x 616 x 660

## Specifications

Model Number	Cond. Unit	Ice Production per 24hrs		Water Usage gallons per 100 lbs of Ice 90°F air/70°F water		kWH Used per 100 lbs of ice @ 90°F air/70°F water	Voltage Characteristics	Min. Circuit Ampacity	Min/Max Circuit Breaker	Approx. BTUs per hour
		70°F air/50°F water lbs (kg)	90°F air/70°F water lbs (kg)	Potable	Condenser					
CIM1446A	Air	1,560 (708)	1,210 (549)	14.4	N/A	4.4	208-230/60/1	19.2	25/30	22,000
CIM1446R	Remote*	1,560 (708)	1,340 (608)	15.0	N/A	4.35		19.9	25/30	
CIM1446W	Water	1,560 (708)	1,440 (653)	14.7	103.9	3.72		18.1	20/25	
CIM1447A	Air	1,560 (708)	1,210 (549)	14.4	N/A	4.4	208-230/60/3	13.7	15/20	21,000
CIM1447R	Remote*	1,560 (708)	1,340 (608)	15.0	N/A	4.35		13.6	15/20	
CIM1447W	Water	1,560 (708)	1,440 (653)	14.7	103.9	3.72		12.6	15/20	

\* Daily ice production based on half cube configuration.

\*\* Remote model CIM1446R and CIM1447R require the RCA-2061 remote condenser with optional grill guard kit.

447R 280 (127) • CIM1447W 300 (136)  
Refrigerant Type: R404A



B1000-48

### Features

- Application storage capacity from 680 lbs (308 kg) to 1660 lbs (753 kg).
- 31" deep for use where space is at a premium.
- Durable stainless-steel construction.
- First-in, first-out ice management for fresher ice.
- Corrosion-resistant poly bin liner.
- Heavy duty "stay-open" door for easy one hand access.
- Ice shield controls flow and reduces spills.

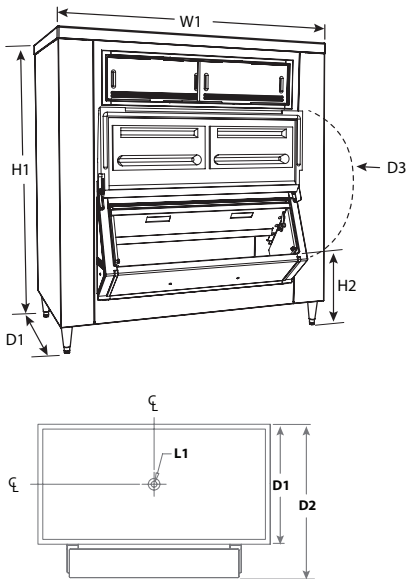

UPRIGHT BIN SPECIFICATIONS	
Maximum Bin Capacity	see model table below
W1 Width	see model table below
D1 Depth	see model table below
D2 Depth with lower door assembly (easily removed for installation access)	add 8.00" (20.32 cm) to D1
D3 Depth with door fully extended	add 18.50" (47.0 cm) to D1
H1 Height (adjustable)	see model table below
H2 Bin sill height	19.00" (48.3 cm)
Required door access	see model table below
L1 Drain Ice compatibility	1" FPT, center of bin bottom
Shipping weight	see model table below
NOTE: For indoor use only	

Model	Maximum Bin Capacity lb (kg)	Cubic Volume cu ft (m)	Width - W1 in (mm)	Depth - D1 in (mm)	Height - H1 in (mm)	Required Door Access in (mm)	Approximate Ship Weight lb (kg)
B700-30	680 (308)	21.7 (0.61)	30 (762)	31 (787)	60 (1524)	31 (787)	212 (96)
B1000-48	1000 (454)	31.9 (0.90)	48 (1219)	31 (787)	56 (1424)	32 (813)	268 (122)
B1300-48	1320 (599)	41.9 (1.19)	48 (1219)	31 (787)	65 (1651)	32 (813)	270 (123)
B1325-60	1325 (601)	42.0 (1.19)	60 (1524)	31 (787)	56 (1424)	32 (813)	320 (146)
B1600-60	1660 (753)	52.8 (1.50)	60 (1524)	31 (787)	65 (1651)	32 (813)	340 (154)



**Single Ice Machine Configurations**

Ice-O-Matic offers a full line of bins for most applications. From low profile slope-front bins to high capacity space-saving uprights, we have a bin to meet any need. The following table will help you create the system you need in a safe and cost effective manner.

Bin Model No.	Style	CIM Series Cube Ice Makers			ICE Series Cube Ice Makers			Pearl Ice® Ice Makers		Flake Ice Machine	
		22" (565 mm) wide	30" (762 mm) wide	48" (1219 mm) wide	22" (565 mm) wide	30" (762 mm) wide	48" (1219 mm) wide	21" (533 mm) wide	30" (762 mm) wide	21" (533 mm) wide	30" (762 mm) wide
B25PP**	Slope Front	KBT19	△	N/A	KBT19	△	N/A	KBT19	△	KBT19	△
B40PS	Slope Front	KBT19	△	N/A	KBT19	△	N/A	KBT19	△	KBT19	△
B42PS	Slope Front	△	N/A	N/A	△	N/A	N/A	KBT24	N/A	KBT24	N/A
B55PS	Slope Front	KBT19	△	N/A	KBT19	△	N/A	KBT19	△	KBT19	△
B110PS	Slope Front	KBT23C	BPF-1***	△	N/A	BPF-1***	△	KBT23C	BPF-1***	KBT23C	BPF-1***
B700-30	Upright	△	△	△	△	△	△	△	△	△	△
B1000-48	Upright	△	△	△	△	△	△	△	△	△	△
B1300-48	Upright	△	△	△	△	△	△	△	△	△	△
B1325-60	Upright	△	△	△	△	△	△	△	△	△	△
B1600-60	Upright	△	△	△	△	△	△	△	△	△	△

\*\* Rotocast finish

\*\*\* BPF-1 used with B110 bins only. If you have an older model B100 use the KBT5.

△ Kit not required

N/A - Ice Machine and Bin Configurator not applicable

**Side-by-Side Ice Machine Configurations**

There are times when it is desirable to install (2) ice machines side-by-side on a bin. The reasons may range from gaining maximum output to creating redundancy. Ice-O-Matic offers an array of kits and bins with custom order tops for just such applications. The following table will help you create the system you need in a safe and cost effective manner.

Bin Model No.	Style	CIM Series Cube Ice Makers		ICE Series Cube Ice Makers		Pearl Ice® Ice Makers		Flake Ice Machine	
		TWO 22" (565 mm) wide	TWO 30" (762 mm) wide	TWO 22" (559 mm) wide	TWO 30" (762 mm) wide	TWO 21" (533 mm) wide	TWO 30" (762 mm) wide	TWO 21" (533 mm) wide	TWO 30" (762 mm) wide
B25PP**	Slope Front	N/A	N/A	N/A	N/A	N/A	N/A	N/A	N/A
B40PS	Slope Front	N/A	N/A	N/A	N/A	N/A	N/A	N/A	N/A
B42PS	Slope Front	N/A	N/A	N/A	N/A	N/A	N/A	N/A	N/A
B55PS	Slope Front	N/A	N/A	N/A	N/A	N/A	N/A	N/A	N/A
B110PS	Slope Front	KBT222	N/A	N/A	N/A	KBT222	N/A	KBT222	N/A
B700-30	Upright	N/A	N/A	N/A	N/A	N/A	N/A	N/A	N/A
B1000-48	Upright	△△	N/A	△△	△△	△△	N/A	△△	N/A
B1300-48	Upright	△△	N/A	△△	△△	△△	N/A	△△	N/A
B1325-60	Upright	△△	KBTF230*	△△	KBTF21506	△△	KBTF230	△△	KBTF230
B1600-60	Upright	△△	KBTF230*	△△	KBTF21506	△△	KBTF230	△△	KBTF230

\* Must use remote or water cooled model only

\*\* Rotocast finish

△△ Kit not required

N/A - Ice Machine and Bin Configurator not applicable

**Bin Accessories**

Ice-O-Matic Part Number	Description
1011517-22	Plastic ice shovel
1011517-23	Hanging bracket for ice shovel
1011517-24	46.5" Plastic paddle
1051517-29	Hanging bracket for ice paddle
9051127-01	82 Ounce ice scoop