



OPERATION MANUAL

CYCLONE SERIES FULL-SIZE GAS CONVECTION OVENS

SERIES: BCO-G & GDCO-G



BUILT BY CRAFTSMEN. TESTED BY TIME®



GAS CONVECTION OVEN OPERATION MANUAL

GAS CONVECTION OVENS

Models:

BCO-G and GDCO-G

All Bakers Pride® convection ovens are intended for use with the type of gas specified on the rating plate and for installation will be in accordance with National Fuel Gas Code ANSI Z223.1 (latest edition).

⚠ WARNING

FOR YOUR SAFETY: Do not store or use gasoline or other flammable vapors or liquids in the vicinity of this or any other appliance.

⚠ WARNING

After the gas supply has been connected to your unit, it is extremely important to check piping for possible leaks. To do this, use soap and water solution or solutions that are expressly made for this purpose. DO NOT USE matches, candles, flames, or other sources of ignition since these methods are extremely dangerous. Instructions to be followed in the event you smell gas should be posted in a prominent location. Obtain these instructions from your local gas supplier.

⚠ WARNING

Initial heating of oven may generate smoke or fumes and must be done in a well-ventilated area. Overexposure to smoke or fumes may cause nausea or dizziness.

⚠ CAUTION

Improper installation, adjustment, alteration, service or maintenance can cause property damage, injury or death. Read the installation, operating and maintenance instructions thoroughly before installing or servicing this equipment.

NOTICE

Instructions to be followed in the event the user smells gas must be posted in a prominent location in the kitchen area. This information shall be obtained from the local gas supplier.

⚠ WARNING

California Residents Only

WARNING: This product can expose you to chemicals including chromium which is known to the State of California to cause cancer and birth defects or other reproductive harm. For more information go to www.P65Warnings.ca.gov.

Please retain this manual for future references.

This equipment is design engineered for commercial use only.



BAKERS PRIDE OVEN COMPANY, LLC.

1307 N. Watters Rd., Suite 180
Allen, TX 75013

(800) 527-2100 Phone | (914) 576-0605 Fax | www.bakerspride.com

P/N 8898500 REV B 2/20



TABLE OF CONTENTS

INSTALLATION INSTRUCTIONS	1	TIMED COOKING ROTARY CONTROL	6
RECEIVING	1	COOK AND HOLD ROTARY CONTROL	6
SET UP/MOUNTING	1	OPTIONAL STEAM INJECTION ROTARY CONTROL	6
INSTALLATION WITH CASTERS (OPTIONAL)	2	TO COOL DOWN THE OVEN QUICKLY	6
LOCATION & MINIMUM CLEARANCES	3	C&H-3 PROGRAMMING/OPERATION	7
GAS CONNECTIONS	3	CLEANING	12
ELECTRICAL CONNECTIONS	4	SERVICING	13
FLUE CONNECTION VENTILATION	4	STACKING INSTRUCTIONS	14
BURNER OPERATION	4	LEG ASSEMBLY INSTRUCTIONS	15
SYSTEM CHECK ROTARY CONTROLS	4	WIRING DIAGRAMS	16
PROGRAMMING MENUS	5	HELPFUL HINTS	19
OPERATING INSTRUCTIONS	5	TROUBLESHOOTING CHART	19
GENERAL INSTRUCTIONS	5	EXPLODED VIEW & PARTS LIST	20
OPERATION SEQUENCE ROTARY CONTROLS	5	WARRANTY	23
COOK ONLY ROTARY CONTROLS	5		

INSTALLATION INSTRUCTIONS

Receiving

Read the notice on the outside carton regarding damage in transit. Damage discovered after opening the carton is "CONCEALED DAMAGE." Carrier must be notified immediately to send an inspector and to furnish forms for claims against the carrier.

When the oven arrives, it should consist of:

- A crate or carton containing your new oven (two for a stacked unit).
- A carton containing four 31" legs with mounting hardware (set of four 6" legs is supplied for stacked installations).
- A carton containing a Flue Adapter and a Draft Hood. Optional: for Direct Venting (Not available for European Community Countries).

Set Up / Mounting

NOTICE

This appliance must be installed by competent personnel in accordance with the rules in force.

In MASSACHUSETTS: All gas products must be installed by a "Massachusetts" licensed plumber or gas fitter. Ventilation hoods must be installed.

Your oven will be packed sitting on its bottom. The skid may be left under the oven for convenience in further handling. Unpack carefully, avoiding damage to the Stainless Steel front and/or trim. If concealed damage is found, follow the instructions detailed in Receiving Section. Keep the area around the ovens free and clear of combustible materials. Do not store any materials on top of or under any oven. The provision of adequate air supply to your oven for ventilation is essential. As a minimum, observe the clearances detailed in the Location & Minimum Clearances section. Provide adequate ventilation and make up air in accordance with local codes. Servicing your oven is done through the front control panel and right side access cover. Ensure that these areas are kept unobstructed for easy access.

For a single unit: Refer to Figure 4

- (1) Tilt Oven over to left-hand side and attach two 31" legs on the right-hand side with three 1/2" bolts and washers. Tighten firmly.
- (2) Using proper lifting equipment, lift up the left-hand side and attach two 31" legs on the left-hand side the same way.

INSTALLATION INSTRUCTIONS

For a stack of two ovens: Refer to Figure 3

- (1) Remove flue from bottom oven prior to stacking. When top oven is properly positioned on bottom oven, re-install the flue back on the bottom oven.
- (2) Tilt lower unit over to the left side and position two 6" legs on the right side (one for front and one for back), secure in place by using 4 bolts (3/8"-16) per leg. Tighten firmly.
- (3) Using proper lifting equipment, lift up the left side of the unit and attach the other two legs in the same way.
- (4) Using the lifting equipment, raise the top oven to proper height and slide on top of the bottom oven. Line up sides and front and fasten to each other at the rear of the units by using a mounting bracket supplied in the stacking kit.

To assemble an open rack stand: Refer to Figure 1

- (1) Loosen 12 bolts (attaching 31" legs) slightly.
- (2) Remove 4 inner bolts, 1 from each of the 4 legs, place top right angle and top left angle underneath and tighten these 4 bolts.
- (3) Insert "Open Rack Shelf" and tighten into place with eight 3/8-16 screws, washers and nuts.
- (4) Position "Rack Supports" and tighten in place using 4 each of flat washers and 5/16-18 Hex Nuts.

Fit the Standard Flue Diverter supplied into the hole in the top of the oven for under ventilation hood installation and secure with screws. For direct venting, Flue Adapter and Draft Hood must be placed into the hole on top of the oven.

Installation With Casters (Optional): Refer To Figure 4

Four casters (two with wheel brakes) and the mounting hardware are packed and included in the shipment if ordered. Install casters with wheel brakes on the front of the unit. Installation of the unit should be made with a connector that complies with the latest edition of the Standard for Connectors for Movable Gas Appliances ANSI Z21.69 in the USA (CAN CSA-6.16 in Canada) and a quick-disconnect device that complies with the latest edition of the standard for quick disconnect devices for use with gas fuel ANSI Z21.41 in the USA (CSA 6.9 in Canada). Adequate means must be provided to limit the movement of the appliance without depending on the connector and any quick disconnect device or its associated piping to limit appliance movement.

The restraint should be attached to the rear legs of the oven on which casters are mounted. If disconnect of the restraint is necessary, the restraint should be immediately reconnected after the appliance has been returned to its originally installed position.

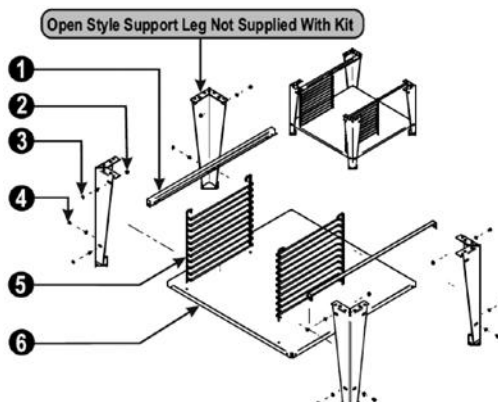

CAUTION
Do not store combustible items or materials on racks

Assembly Instruction

1. Place undershelf (6) between legs & secure with 1 1/4-20 UNC screws (4), flat washers (3) & locknuts (2). The holes for mounting the wire racks should be toward the front of the oven.
2. Place open rack supports (1) between legs & secure with 1/4-20 UNC screws (4), flat washers (3) & locknuts (2).
3. Slide wire rack supports (5) into position using the holes in the undershelf (6) as a guide.

Item	P/N	Description	Qty
1	21818232	Support, Open Rack	2
2	770504	Lock Nut 1/4-20	12
3	8519600	Washer, Flat 1/4"	12
4	8208200	Screw, 1/4-20 x 3/4"	12
5	21816807	Support, Wire Rack	2
6	21818220	Undershelf, Gas Oven	1

Figure 1: Open Rack Stand Assembly Instructions, BCO-G & GDCO-G



INSTALLATION INSTRUCTIONS

Location and Minimum Clearances:

Move the oven to its final location keeping the minimum clearance from the back of the oven to the wall.

This clearance is necessary for safe operation and to provide proper air flow to the burner chamber.

Minimum Clearances From Combustible and Non-combustible Construction		
	Under Ventilation Hood	Direct Venting
Right Wall	1"	1"
Left Wall	1"	3"
Rear Wall	3"	3"

Suitable for installation on combustible floor when installed with legs or casters provided.

! CAUTION

Do not set the oven with its back flat against the wall. It will not operate properly unless there is at least three inches breathing space behind the oven.

Gas Connection:

The ovens should not be installed on the same gas supply line with space heaters, boilers or other gas equipment with high intermittent demand.

The installation of the oven must conform to the latest local codes or National Fuel Gas Code, ANSI Z223.1, Natural Gas Installation Code, CAN/CGA-B149.1, or the Propane Installation Code, CAN/CGAB149.2.

The appliance must be isolated from the gas supply piping system by closing its manual shutoff valve during any pressure testing of the gas supply piping system at test pressures equal to or less than 1/2 psig (3.45kpa). The appliance and its shut-off valve must be disconnected from the gas supply piping system during any pressure testing of that system at test pressures in excess of 1/2 psig (3.45kpa).

Use a pipe joint compound that is resistant to the action of liquefied petroleum gases when making gas connections. For Propane gas, use at least 1/2" (13 mm) pipe or tubing with a 5/8" (16 mm) inside diameter. For Natural gas, use 3/4" (19 mm) pipe.

The gas pressure regulator is part of the combination valve and is adjusted to yield a pressure of 3.5" water column (9 mbar) for Natural Gas. If the oven is ordered for use on Propane Gas or Butane, the pressure regulator in the combination valve is preset at the factory to yield a pressure of 10" water column (25 mbar).

NOTICE

No external regulator is required.

Gas supply pressure in the European Community countries should be as below.

Gas Type	Supply Pressure
G20	20 mbar
G25	25 mbar
G20/25	20/25 mbar
G30	30 or 50 mbar depending on country
G31	30, 37, or 50 mbar depending on country

A separate shut-off valve for each oven must be provided. It should be as close as possible to the place where the gas line goes into the oven. It must be located such that it is easily accessible. When stacking with another oven, two shut-off valves, one for each of the two ovens, must be provided.

After the Gas Supply has been connected, it is extremely important to check all the piping for leaks. Use soap and water solution or a product expressly made for this purpose. Do not use matches, candles or a flame and so forth to check leaks since these methods are extremely dangerous.



INSTALLATION INSTRUCTIONS

Electrical Connection:

The oven, when installed, must be electrically grounded in accordance with local codes and/or the latest edition of the National Electrical Code ANSI/NFPA No. 70 in the USA (Canadian Electrical Code CSA Standard C22.1, Part 1 in Canada).

In Europe, the appliance must be connected by an earthen cable to all other units in the complete installation and hence, to an independent earth connection in compliance with EN 60335-1 and/or local codes.

The electric motor, all the related switches, interior lights, and the timer/buzzer are all connected through the 6-foot (1829 mm) power supply cord located at the rear of the oven. The supply cord must be plugged into a properly grounded, three-prong receptacle. **DO NOT CUT OR REMOVE THE GROUNDING PRONG FROM THE PLUG.**

Normal factory connections are made for 120 volts A.C., 60 hz, Service in USA and Canada or 240 volts A.C., 50 hz service in European community countries. Other voltages can be supplied upon request. Electrical characteristics of this unit can be found on the rating plate located on the right side of the unit.

This unit is provided with a permanently lubricated electric motor. A wiring diagram may be found on the back of the service panel on the right-hand side and in this manual.

Flue Connection Ventilation:

Installation Under Ventilation Hood (Standard):

If the oven is not vented directly and is installed under a ventilation hood, the unit is ready to be installed as is. Local inspectors and ventilation specialists should be consulted so that the design and the installation of the hood conform to local/municipal codes. In the U.K., follow ventilation requirements as detailed in B.S. 5440.

Optional Direct Venting

(Not Available For European Community Countries):

If direct venting, a flue adapter and a draft hood are required to be installed. They prevent the flue gases leaving the oven to be affected by the air pressure changes on the outside of the flue stack extending out of the building. The flue pipe from the draft hood

must not run downwards at any point from the oven to the final outlet. It should always slant slightly upwards. For best results, it should rise straight up. The venting system shall be in accordance with the National Fuel Gas Code, ANSI Z223.1 / NFPA 54 and or the CSA B149.1, Natural Gas and CSA B149.2, Propane Installation Codes, and local codes.

NOTICE

Do not put a damper in the flue and do not connect a blower directly to the flue.

If the flue runs directly to the free air outside the building, use a wind deflector or a UL listed vent cap at the end of the pipe. Termination of the vent must be at least two feet above the highest part of the roof within ten feet. REF: AGA CATALOG NO. XH0474.

Burner Operation:

The oven burner flame should always have a blue appearance. This indicates a good mixture of air and gas. When using LP gas, the flame will have a blue-yellow appearance. There may be intermittent yellow-orange flame noticed. This is caused by dust particles burning in the flame.

System Check- Rotary Control:

- 1) Open the oven door.
- 2) Turn Selector Switch to "HI." The indicator light near Selector Switch and oven light will illuminate.
- 3) Close the door. Oven lights will go off and fan will run. Make sure fan is rotating clockwise looking from front.
- 4) Press Oven Light switch. Oven light will go on and will go off when switch is released.
- 5) Turn Gas Cock Dial to "ON" position (only for USA and Canada).
- 6) Turn the thermostat knob. The indicator light near the thermostat will illuminate and the burners will come on.
- 7) Turn the Timer Knob and set a time of 2 minutes. At the end of 2 minutes, you should hear the buzzer. Turn the timer knob to "0", to stop the buzzer.



INSTALLATION INSTRUCTIONS

- 8) Open the oven doors. Oven lights will go on and burners and fan will go off.
- 9) Turn Selector Switch to “Cool Down” position. The fan will run to cool down the oven.
- 10) Turn Selector Switch to “0” position.
- 11) Close the oven doors.

NOTICE

Oven starts heating as soon as the set temperature is higher than the oven temperature w/oven doors closed & the selector switch not in “0” position. Thermostat indicator light goes out when oven reaches set temperature and comes on when oven is heating up.

In the event of power failure, the oven will not operate. Restoration of power after any duration will return unit to normal operation.

Programming Menus (For Units With Digital Controls):

Refer to C&H -3 Plus Controller Operating/ Programming Instructions Manual.

OPERATING INSTRUCTIONS

General Instructions:

- 1) This equipment has an Electronic Temperature Control and Electronic Hot Surface Direct Ignition System.
- 2) Due to increased efficiency of this oven, the temperature of standard recipes may be reduced 50°F (30°C).
- 3) Always load each shelf evenly. Space pans away from each other and from sides and back of oven to allow maximum airflow between them.
- 4) Large tempered glass windows and interior lights allow a close check on the product, making it unnecessary to frequently open the doors. Products cook faster in a convection oven as compared to a conventional oven. Depending on the product and the type of pans used, time saving may run from 20 percent to as high as 50 percent.

Operation Sequence Rotary Control:

Cook Only Rotary Control:

- 1) Close the oven doors.
- 2) Turn Selector Switch to “HI” or “LO” position. The indicator light near the Selector Switch will light.
- 3) Turn the thermostat knob to the desired cooking temperature.
- 4) Upon reaching the set temperature, the indicator light near the thermostat will go out.
- 5) Load the oven with product to be cooked.
- 6) Remove the product from the oven when done.



OPERATING INSTRUCTIONS

Timed Cooking Rotary Control:

- 1) Close the oven doors.
- 2) Turn Selector Switch to “HI” or “LO” position. The indicator light near the Selector Switch will light.
- 3) Turn the thermostat knob to the desired cooking temperature.
- 4) Upon reaching the set temperature, the indicator light near the thermostat will go out.
- 5) Load the oven with product to be cooked.
- 6) Turn the timer knob to the desired bake time and timer will start counting down.
- 7) When timer reaches zero, a buzzer will sound.
- 8) Turn the timer knob to “O” position.
- 9) Remove the product from the oven.

NOTICE

Timer is a signal device only and does not control the oven.

Cook and Hold Rotary Control:

- 1) Close the oven doors.
- 2) Turn Selector switch to “HI” or “LO” position. The indicator light near the Switch will be illuminated.
- 3) Turn the thermostat knob to the desired cooking temperature.
- 4) Upon reaching the set temperature, the indicator light near the thermostat will go out.
- 5) Load the oven with product to be cooked.
- 6) Turn the timer knob to the desired bake time and timer will start counting down.
- 7) When timer reaches zero, a buzzer will sound.
- 8) Turn the timer knob to “O” position.
- 9) Turn the thermostat knob to the desired hold temperature.
- 10) Remove the product from the oven when needed.

Optional Steam Injection: Rotary Control:

The solenoid valve for steam injection is mounted behind the service panel on the right-hand side of the unit. The electronic timer is preset at the factory. A 1/4” copper tubing is provided on the Solenoid Valve for water hookup with a compression fitting. After the water hookup is made, make sure that there are no leaks. For steam injection, press the Steam switch momentarily.

NOTICE

Do not use steam injection at temperatures below 275°F (135°C).

Oven Cool Down Rotary Control:

To cool down the oven to a lower desired temperature, follow the steps detailed below.

- 1) Open the oven doors.
- 2) Turn Selector Switch to “Oven cool down” position. Fan will now operate and cool down the oven.
- 3) When the oven has cooled down to the desired temperature, turn the Selector Switch to “O” position. Close oven doors.

OPERATING INSTRUCTIONS

**Operating/Programming Instructions -
Cook & Hold-3 Plus™ Controller (For Convection
Ovens: C011-G, C011-E, COCE, GDCO-G & GDCO-E)**

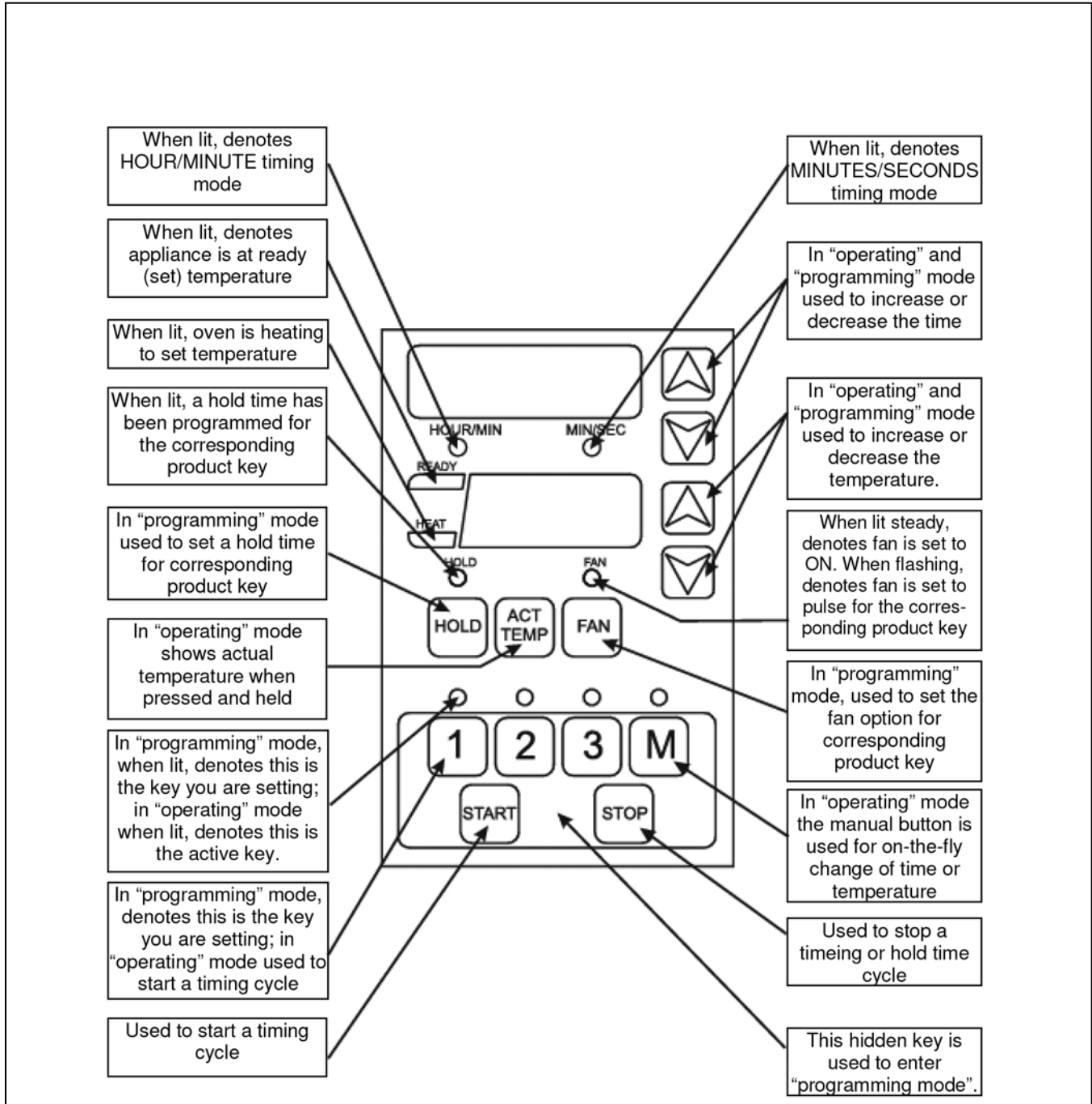

Controller Key Description

OPERATING INSTRUCTIONS

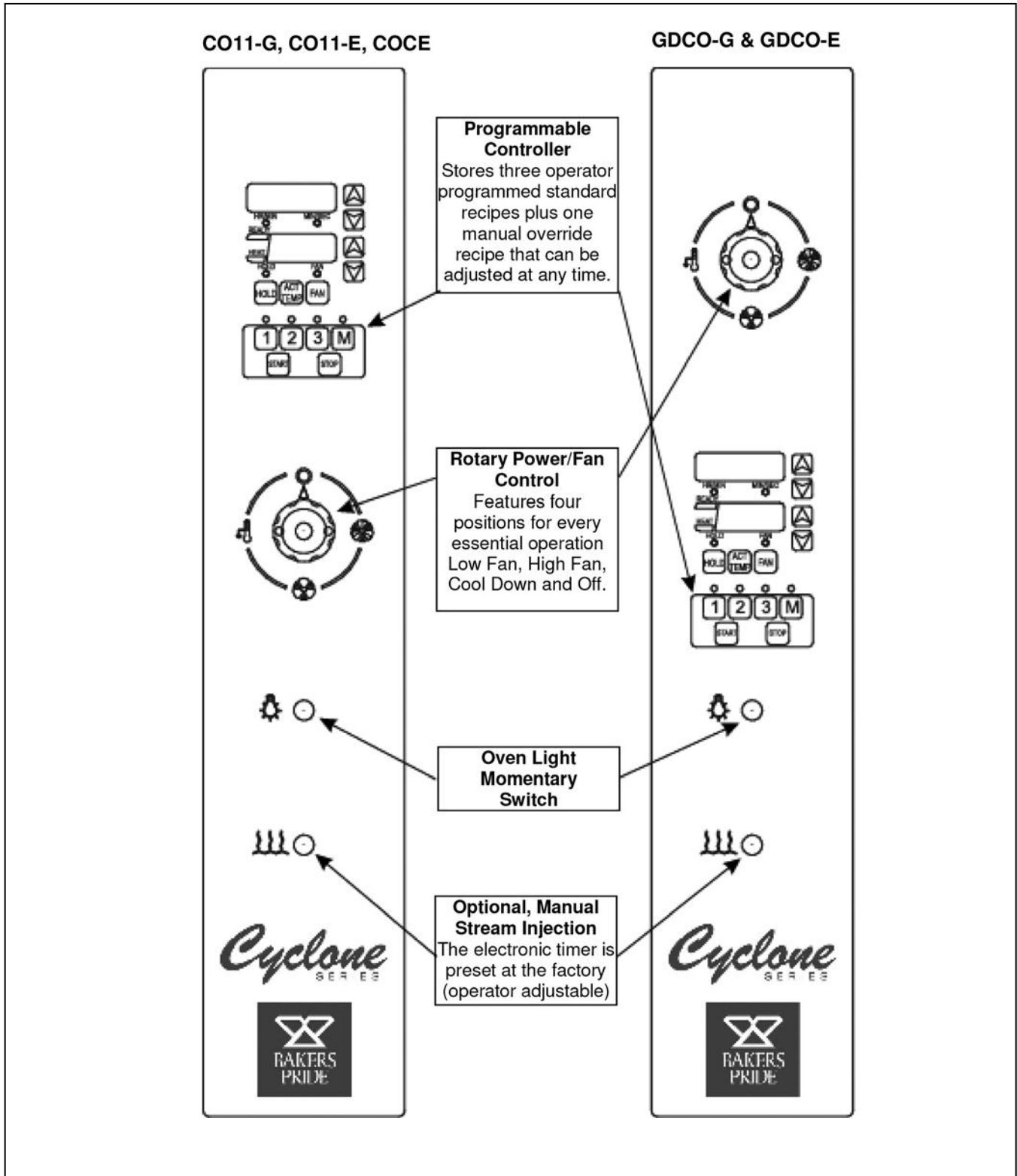

OPERATING INSTRUCTIONS

Operating Instructions

There are 3 programmable times & temperatures, and 1 manual override time & temperature setting. The timing range of all keys is from: 01 second to 99 hours (automatically switches from min/sec. to hour/min). Each key is also programmable for one hold time and a two-position fan (on/pulse).

In normal operating mode, the READY LIGHT (LED) will illuminate when the oven temperature is +20°F of set temperature. The HEAT LIGHT (LED) will illuminate when actual temperature is below set temperature and the unit is calling for heat.

Once set and actual temperatures are equal, key 1, 2, 3 or M may be pressed. The light above the corresponding key will be lit. Pressing the START key will begin a flex time countdown (time is compensating) depending on temperature.

Optional Steam Injection

The solenoid valve for steam injection is mounted behind the service panel on the right-hand side of the unit on COC-E and on back of the unit on CO11 -E/G. The electronic timer is pre-set at the factory and may be adjusted by operator if required for shorter or longer steam burst. For steam injection, press the steam injection switch.

Oven Cool Down

To cool down the oven to a lower desired temperature, follow the steps detailed below: Open the oven door(s). Turn selector switch to “Oven Cool Down” position. Fan will now operate and cool down the oven. When the oven has cooled to the desired temperature, turn the selector switch to the “0” position.

Operating Notes

When the oven is turned on it will automatically preheat to set temperature if the door is closed. If the door is opened while program is running, the cook cycle will pause and the display will flash. When the door is closed, the display will return to the count down from where it was paused.

Starting A Cook Cycle

 To start a cook cycle, simply turn selector switch to LO or HI position and press the product key for the product you wish to cook. If the product key is programmed, the correct cooking time will be displayed 12:00 (example). Press the START key and the time will immediately start to count down in minutes and seconds. If :00 is displayed immediately and the unit starts to signal, the key being operated is not programmed. If correctly programmed, it will count down to :00. When zero is reached, the light above the product key will be flashing, the controller will emit an audible alarm and immediately begin counting up (if programmed for a hold time).

 Cancel this alarm by pressing the stop key; controller will continue to count up.

Holding Timers

If the unit is programmed with a holding time, the holding time will automatically start counting upon expiration of the cooking cycle. When there is an active hold time, the HOLD indicator will be lit and the light above the product key with the hold time will be flashing.

To cancel, press the  key.

Display Descriptions

 The unit is in the Operating Mode. The actual temperature is shown in the display and is within 20 degrees of the programmed temperature.

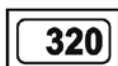
 The unit is in the Operating Mode. The actual temperature will flash in the display and is more than 20 degrees below the programmed temperature range.

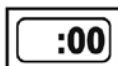
 The unit is in the Operating Mode. The flashing display signifies a cook cycle has just been completed.

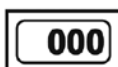
 The unit is in the Operating Mode. With three zeros displayed, the probe has failed, or the appliance has gone beyond operating temperature. Shut the appliance OFF immediately and call a technician.

OPERATING INSTRUCTIONS

Controller Features

Fahrenheit or Celsius Temperature Display

The operator is allowed to configure the controller to display the temperature in degrees Fahrenheit or Celsius from the jumper on the back of the circuit board (J3). By default, the unit is shipped from the factory in Fahrenheit (J3 not shorted), unless otherwise specified by the customer. For Celsius display, power unit down, remove jumper from Pin 1 and short both pins. When power is re-applied, the controller will be in Celsius operation.

Programmable Times

The operator will have the ability to program the cook times for each product key. The controller is programmable in minutes (up to 59) and seconds (up to 59), then hours (up to 99).

Programmable Temperatures

The operator will be able to program cook temperatures for each product key. The valid temperature range is 150 to 550°F (66 to 288°C).

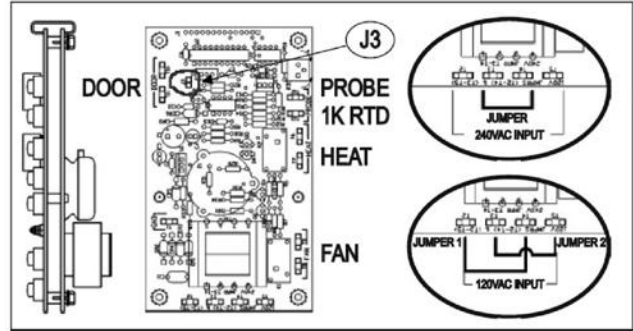

Programmable Hold

The operator will be able to program each product key for a counting hold time and temperature (140 to 200°F/60 to 94°C) or disable the hold mode.
 HOLD LIGHT (LED) ON = hold mode enabled
 HOLD LIGHT (LED) OFF = hold mode disabled

Programmable Fan

The operator will be able to program each product key for one of two fan modes.
 FAN LIGHT (LED) ON = Fan always ON
 FAN LIGHT (LED) Flashing = Fan pulsed

Flashing Display

The temperature display will flash after every product key is pressed. The display will continue to flash until the actual temperature is within 20° of set temperature.



OPERATING INSTRUCTIONS

Programming the Oven Controller

The following steps are needed to enter and program each of the product keys. Please note that you must follow each of the steps below for each product key.

NOTICE

The manual “M” key allows you to temporarily change the set temperature & time and will reset to the original programming parameters after you are done cooking. This key is programmed the same as keys 1, 2 & 3 except that programming mode does not have to be entered to do it. However, you can still manually program the controller while in programming mode.

		Action	Result
		Press the product key you want to program.	The corresponding LED will light above the selected product key.
		Enter the programming mode by pressing and holding the area between the START and STOP keys until the light above the product key starts flashing (approx. 3 seconds).	You have successfully entered the programming mode.
		To set the cooking time, press the up and down arrow key to the right of the display.	The longer you press the key, the faster the display will change.
		To set the cooking temperature, press the up and down arrow key to the right of the temperature display.	The longer you press the key, the faster the display will change.
		To select the hold feature and set the holding temperature, press and hold the HOLD key, then use the up or down arrow to the right of the temperature display to select your holding temperature.	This will activate the holding feature and set the holding temperature. NOTE: The light above the HOLD key will be on if you have set the hold feature correctly.
		To select the fan operation, press the FAN key until the mode you want is displayed.	1. The light above the FAN key is on, the fan will be ON when door is closed. 2. The light above the FAN key is flashing, the fan will ONLY be ON when the heat goes ON.
		To exit the programming mode, press the space between the START and STOP keys.	The product key light will be on steady, and the program will be saved.

Portions of this instruction manual pertaining to the CH-100 controller are reprinted with the permission of Food Automation-Service Techniques, Inc. (Fast).
© 2001 Bakers Pride Oven Co., Inc. All rights reserved.



OPERATING INSTRUCTIONS

Cleaning

Always clean equipment thoroughly before first use. Clean unit daily.

⚠ WARNING

To avoid any injury, turn the power switch off at the fuse disconnect switch/circuit breaker or unplug the unit from the power source and allow to cool completely before performing any maintenance or cleaning.

⚠ WARNING

Unit is not waterproof. To avoid electrical shock or personal injury, DO NOT submerge in water. DO NOT operate if it has been submerged in water. DO NOT clean the unit with a water jet. DO NOT steam clean or use excessive water on the unit.

⚠ CAUTION

Use mild detergent or soap solution for best results. Abrasive cleaners could scratch the finish of your unit, marring its appearance and making it susceptible to dirt accumulation. DO NOT use abrasive cleaners or cleaners/sanitizers containing chlorine, iodine, ammonia or bromine chemicals as these will deteriorate the stainless steel and glass material and shorten the life of the unit. Use nylon scouring pads. DO NOT use steel wool.

Oven Interior:

Clean The Racks And Rack Support Guides:

Open the doors and remove all wire racks and rack support guides. Take them to the sink and thoroughly clean in warm water with mild detergent or soap. Use a nylon scouring pad or stiff nylon brush. Do not use steel wool.

Clean The Stainless Steel Interior:

Baked on splatter, oil, grease or discoloration on the stainless steel inside of the oven may be removed with stainless steel cleaner, or any other similar cleaning agent. NEVER use vinegar or any corrosive cleaner. Use only cleaners approved for stainless steel. NEVER use cleaning solvents with a hydrocarbon base. NEVER use a wire brush, steel or abrasive scouring pads, scraper, file or other steel tools. Note: Always rub the stainless steel along the grains.

Clean The Blower Wheel:

To clean the blower wheel, remove and immerse in ammoniated water for 20 to 25 minutes. Then, scrub it off with a small, stiff brush. The same procedure can be followed for wire racks and rack supports. To remove the blower wheel, loosen the set screws (2) on the hub of the blower wheel and tighten the 3/8" wheel puller bolt (supplied) in center of hub (See Fig. 2).

Clean The Porcelain Interior:

Porcelain enamel interiors are designed to be as maintenance free as possible. However, for best results, the oven should be cleaned regularly. Enameled interiors can be easily cleaned with oven cleaners. Keep cleaning fluids away from electrical wires, light sockets, switches and control panel.

Oven Exterior:

Clean The Exterior Stainless Steel:

To remove normal dirt or product residue from stainless steel, use ordinary soap and water (with or without detergent) applied with a sponge or cloth. Dry thoroughly with a clean cloth. Never use vinegar or corrosive cleaner. Do not use chlorine based cleaners.

To remove grease and food splatter or condensed vapors that have baked on the equipment, apply cleaners to a damp cloth or sponge and rub cleanser on the metal in the direction of the polished lines on the metal. Rubbing cleanser as gently as possible in the direction of the polished lines will not mar the finish of the stainless steel. To remove discoloration, use a non-abrasive cleaner. NEVER use a wire brush, steel or abrasive scouring pads, scraper, file or other steel tools. Never rub with a circular motion.

OPERATING INSTRUCTIONS

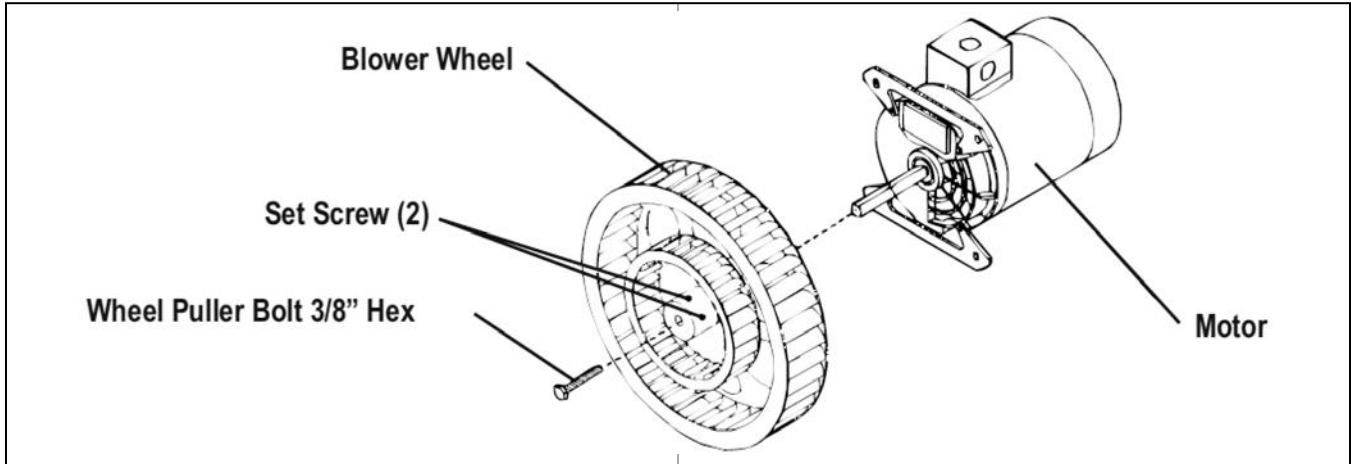

Figure 2: Cleaning The Blower Wheel

Servicing:

NOTICE

This appliance must be serviced by an authorized service agent.

- 1) Power supply to the unit must be disconnected before any service is performed.
- 2) Most of the service on the unit can be performed from the front and/or control panel side.
- 3) For proper servicing, access to the control panel side of the unit will be required.
- 4) It will be necessary to have access to the back of the oven for service needs related to the electric power supply.
- 5) A system wiring diagram is provided in this manual and on the back of the service panel on the right side of the oven.
- 6) This unit is provided with a permanently lubricated electric motor.
- 7) All servicing should be performed by a factory-authorized technician only.

- 8) For Proper maintenance and repairs, call the factory toll free (800-431-2745) for an authorized service agency in your area.

NOTICE

The ventilation system must be inspected at least every six months and maintained clean and free of obstructions.

Front Trim Removal Instructions

- 1) Remove the two screws holding the top of the front panel in place.
- 2) Tilt the front panel forward.
- 3) Remove the tab at the bottom of the front panel from the slot in the bottom trim.
- 4) Open the doors.
- 5) Remove the screws in the top of the bottom trim.
- 6) Lift the bottom trim straight up approximately 1/4".
- 7) After the bracket on the inside of the front trim has cleared the flange on the base, pull the bottom trim away from the oven to remove.

OPERATING INSTRUCTIONS

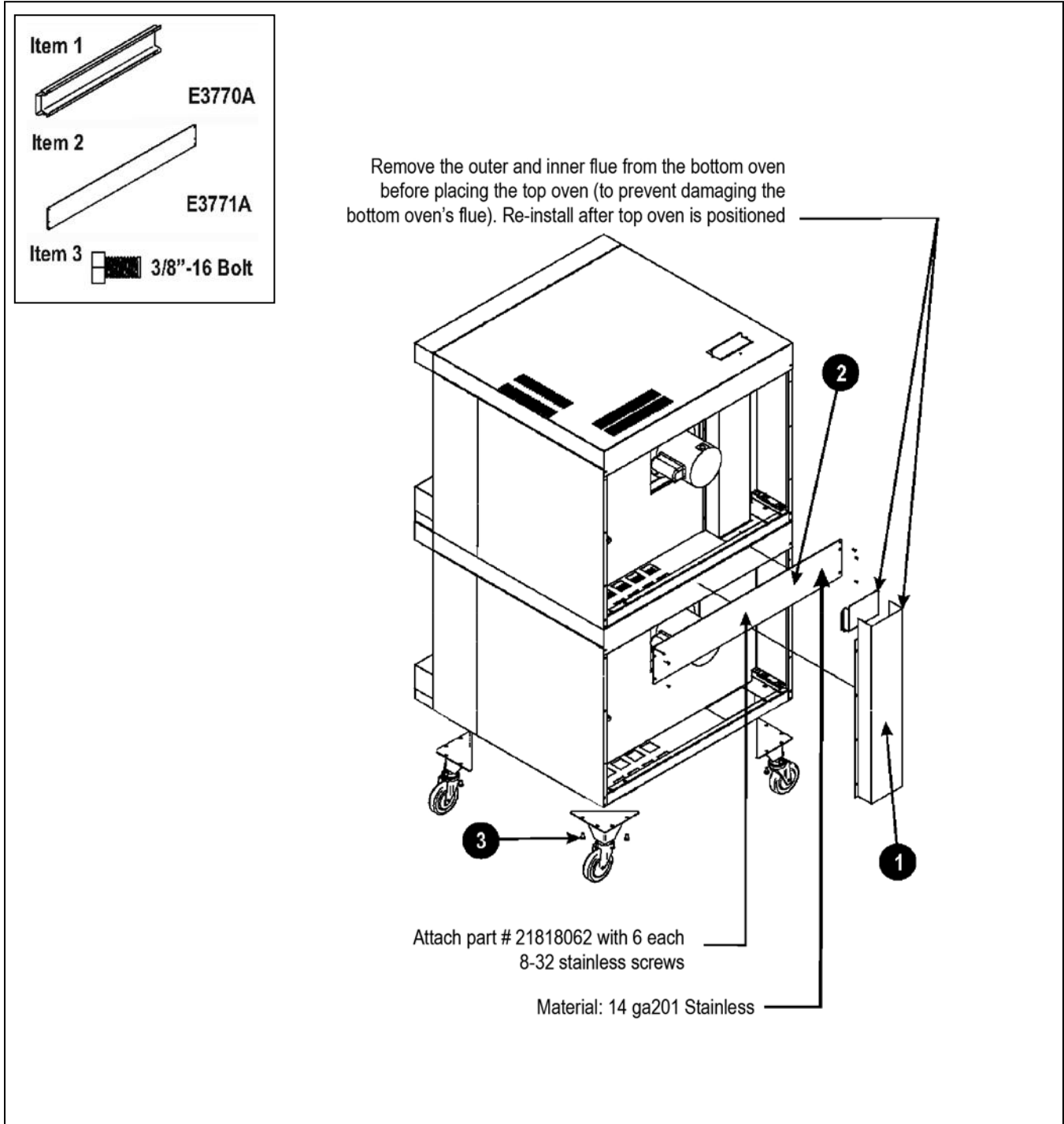

Figure 3: Stacking Instructions For: BCO-G & GDCO-G Convection Ovens

OPERATING INSTRUCTIONS

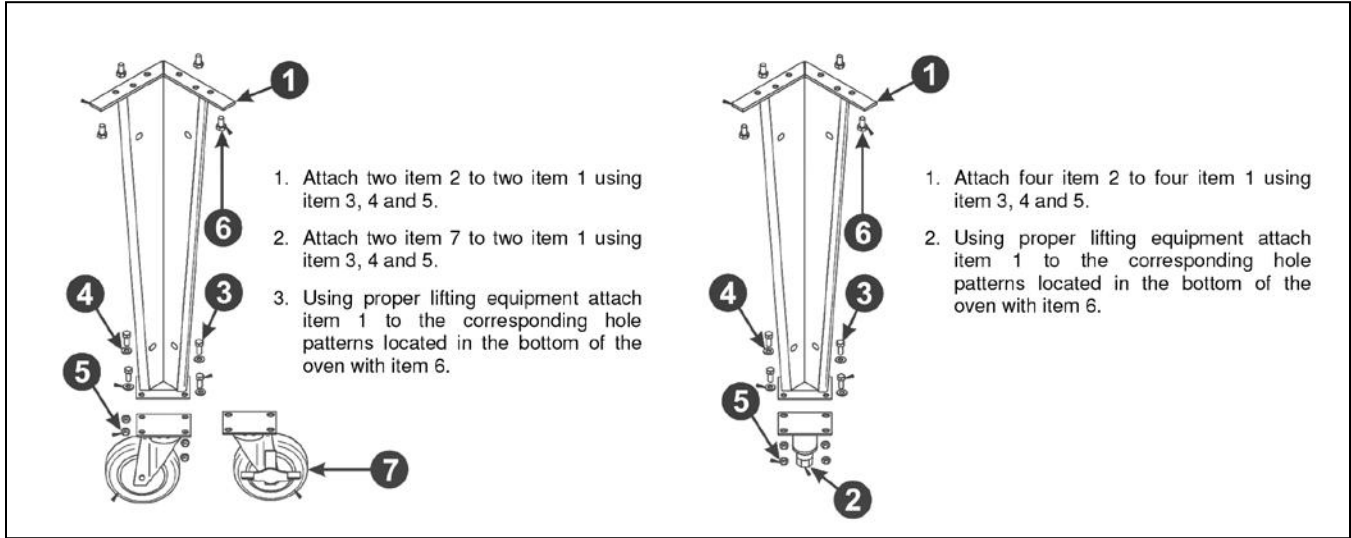

Figure 4: Leg Assembly Instructions - Model: BCO-G & GDCO-G

Item	P/N	Description
1	21796810	Weldment, Oven Leg
2	8633102	Caster, 5" Swivel W/Top Plate
3	8227700	Hex Hd 5/16-18 X 3/4 Bolt #5 Zn
4	8509300	Washer, Flat SAE, 5/16
5	8435000	Hex-nut 5/16-18
6	82447-00	Hex Hd. 3/8-16 X .750 #5
7	8633101	Caster, 5" Swivel W/Plate & Brake

Without Plate Caster

Item	P/N	Description
1	21796810	Weldment, Oven Leg
2	8633515	Foot Insert, Adjustable
3	8227700	Hex Hd 5/16-18 X 3/4 Bolt #5 Zn
4	8509300	Washer, Flat SAE, 5/16
5	8435000	Hex-nut 5/16-18
6	82447-00	Hex Hd. 3/8-16 X .750 #5

OPERATING INSTRUCTIONS

Wiring Diagrams

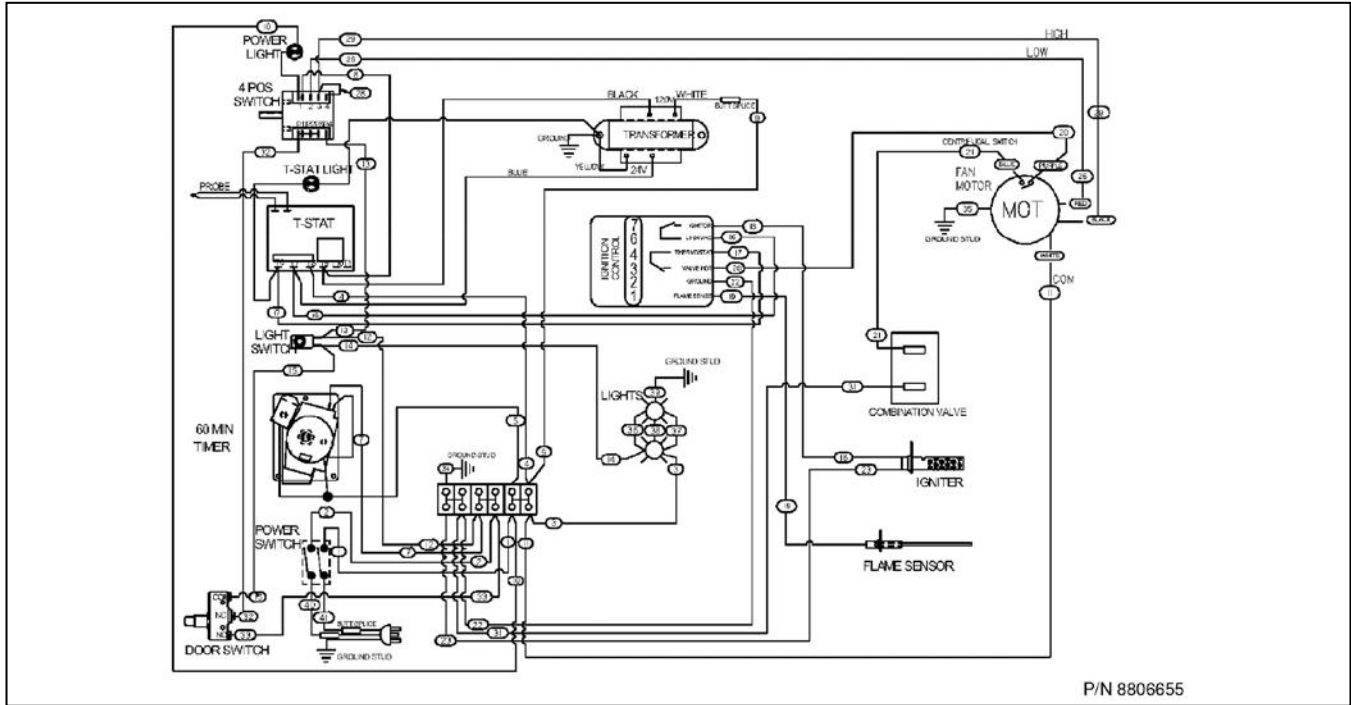

Wiring Diagram – BCO-G & GDCO-G 120V, 1 Phase (Dial Control)

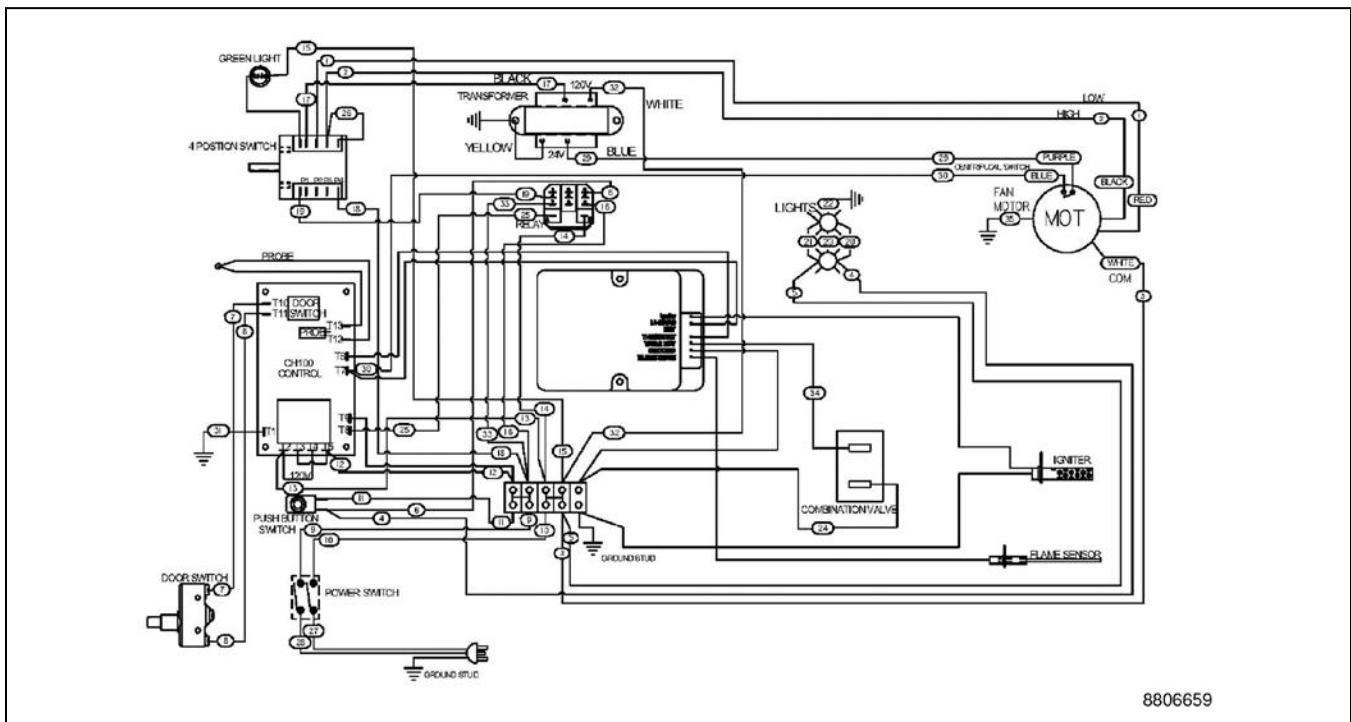

Wiring Diagram – GDCO-G 120V, 1 Phase (Push Button Control)

OPERATING INSTRUCTIONS

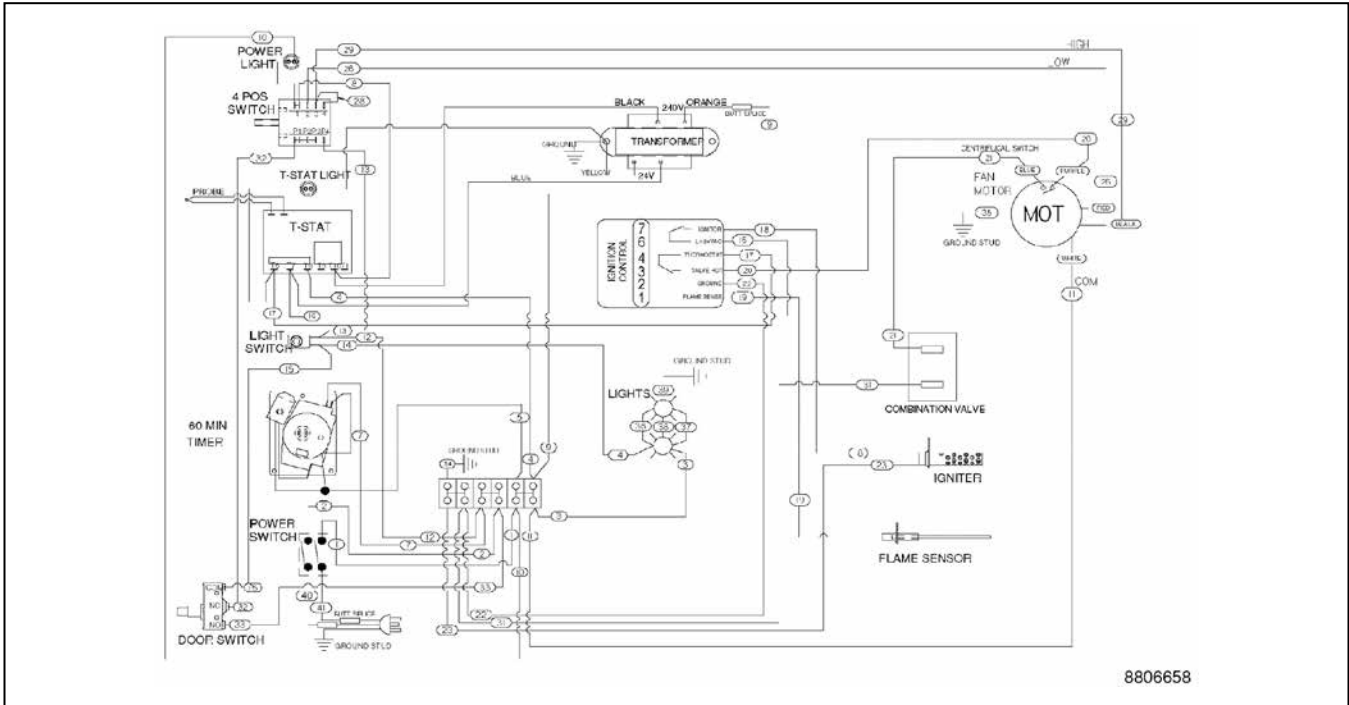

Wiring Diagram – BCO-G & GDCO-G 240V, 1 Phase (Dial Control)

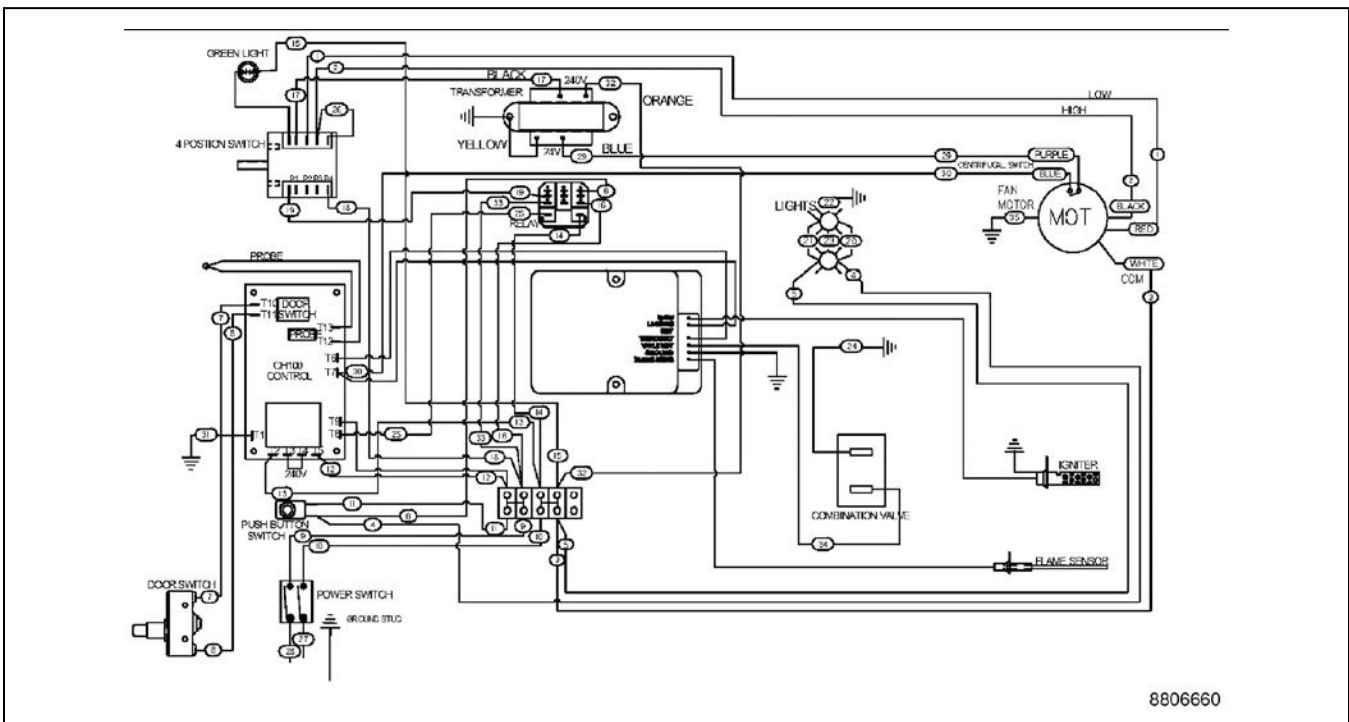

Wiring Diagram – GDCO-G 240V, 1 Phase (Push Button Control)

OPERATING INSTRUCTIONS

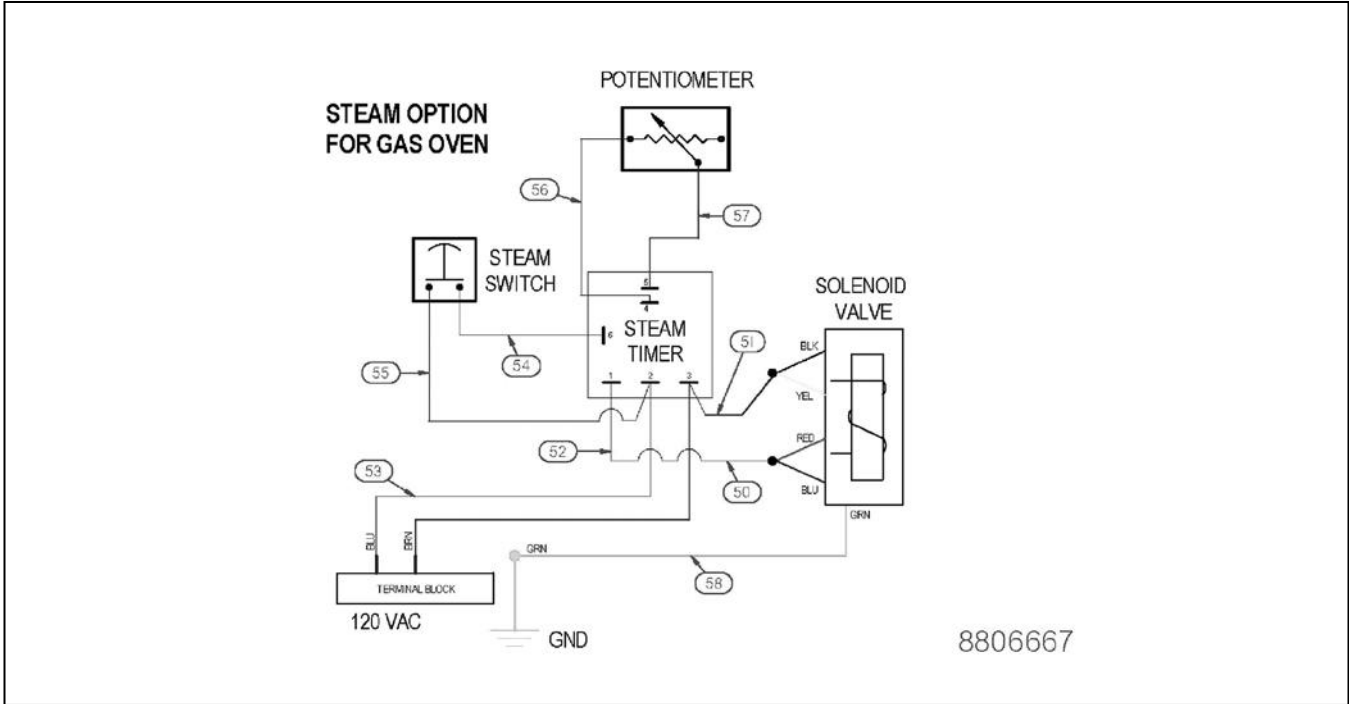

Wiring Diagram – Steam Injection 120V

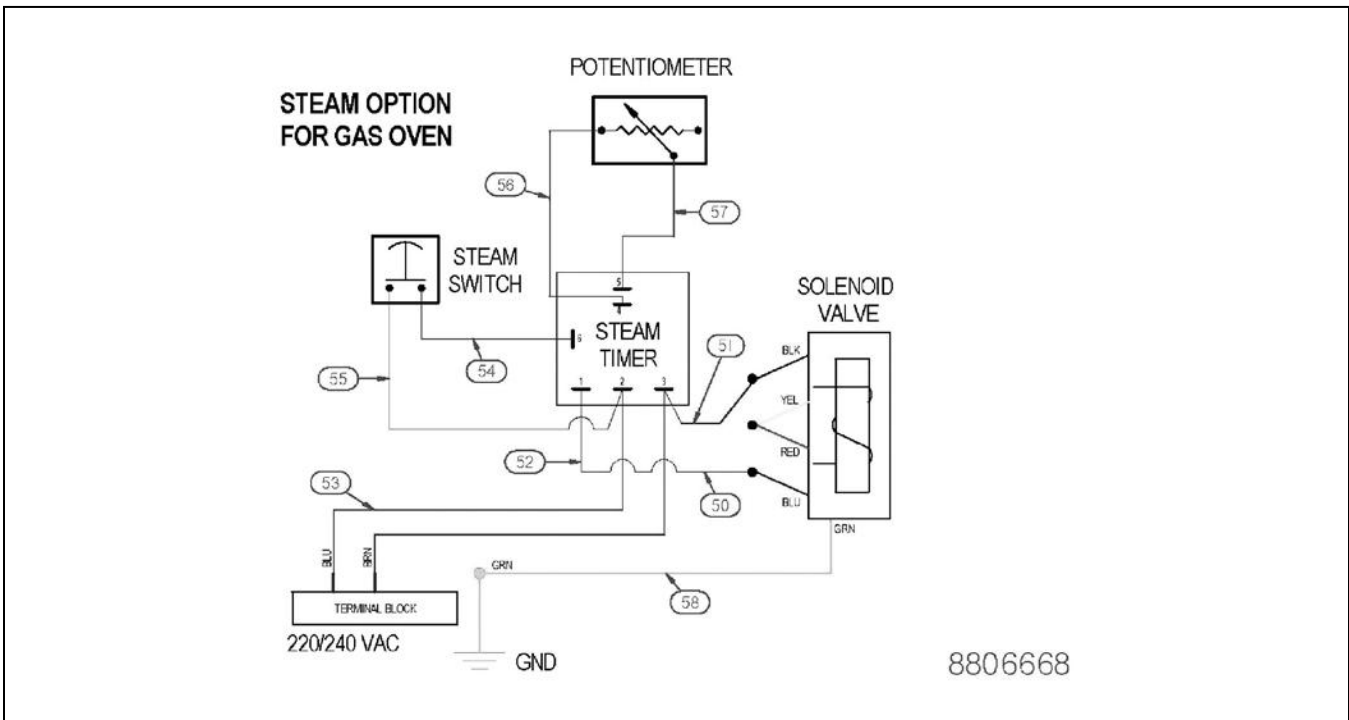

Wiring Diagram – Steam Injection 220/240V



GAS CONVECTION OVEN OPERATION MANUAL

OPERATING INSTRUCTIONS

HELPFUL HINTS		
PROBLEM	CAUSE	SOLUTION
Food browns unevenly	Improper heating temperature.	Preheat until desired temperature is reached.
	Aluminum foil on rack or oven bottom.	Remove foil.
	Several pans crowded together.	Center pans on racks, or leave more space between all pans and oven walls.
	Baking pans too large.	Use smaller pan.
	Baking pan dark or glass.	Lower oven temperature 25°F (-3.8°C) for this type of pan.
Food dries before browning	Oven temperature too high	Lower oven temperature
	Oven door opened too frequently	Check food a minimum number of times.
	Pans too deep	Use a cookie sheet (not a baking pan).
	Dark cookie sheet	Use light, shiny cookie sheet.
	Oven temperature too high	Lower oven temperature
Cookies too flat	Hot cookie sheet	Allow cookie sheet to cool between batches.
Cake too brown on bottom or crust forms on bottom	Oven temperature too high.	Lower temperature; if using glass or dark pan, lower 25°F (-3.8°C)
Cakes have light outer color	Thermostat set too low.	Raise temperature
Cake settles slightly in the center.	Bake time too short or bake temperature too low.	Bake longer or raise oven temperature slightly. Do not open doors to oven for long periods.
Cake ripples	Overloading pans or batter is too thin	Reduce pan loads. Thicken batter.
Cakes are too coarse	Thermostat set too high.	Lower oven temperature.
Pies have uneven color	Too many pies per rack.	Reduce number of pies per rack or eliminate use of bake pans.
Cupcakes crack on top	Thermostat set too high.	Lower oven temperature.
Meats are browned & not done in the center	Thermostat set too high.	Lower oven temperature and roast longer.
Meats are well done and not browned	Thermostat set too low.	Raise temperature. Limit amount of moisture.
Meats develop hard crust	Thermostat set too high.	Reduce temperature or place pan of water in oven
	Fan is set on high speed	Set fan to low speed
Oven cycles 3 times & locks itself out	Flame Sensor defective	Call Bakers Pride factory authorized service center

TROUBLESHOOTING CHART		
PROBLEM	CAUSE	SOLUTION
No heat	Igniter defective	Call Bakers Pride factory authorized service center
	Power switch on control panel is off.	Set the control panel to COOK or OVEN ON.
	Doors are open	Close doors
	Door Micro-Switch defective.	Call Bakers Pride factory authorized service center
	Gas valve to oven may be in the closed position	Turn gas valve on.
Oven does not come to ready.	The oven has not reached preheat temperature.	Wait for oven to reach preheat temperature.
	Internal problem with main temperature control.	Call Bakers Pride factory authorized service center
Convection fan does not run.	Oven has no electrical power.	Check electrical supply.
	Circuit breaker tripped.	Reset the breaker.
	Doors are open	Close doors.
	Door Micro-Switch defective.	Call Bakers Pride factory authorized service center

EXPLODED VIEW & PARTS LIST

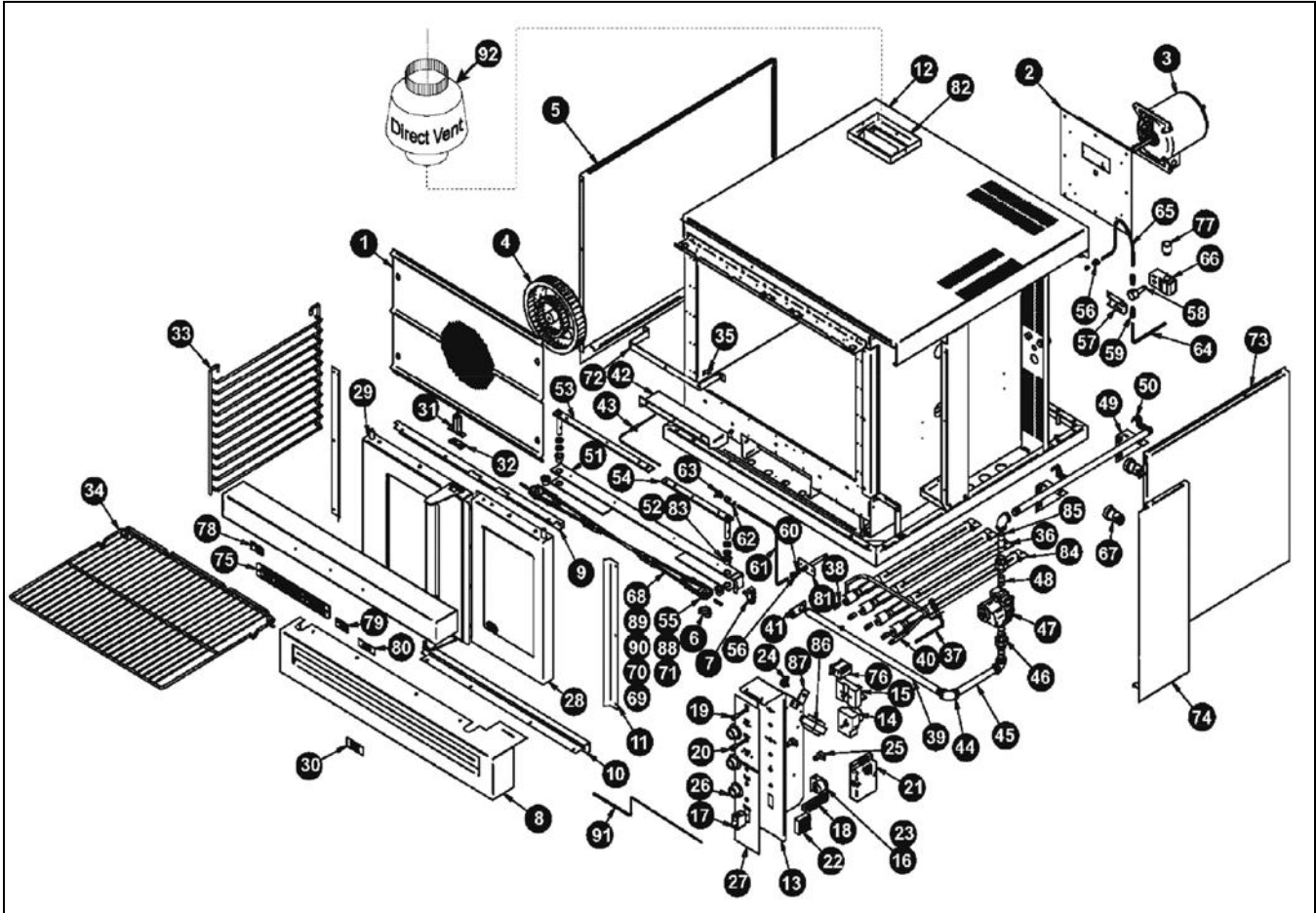

Exploded View

Not Shown

P/N	Description
E8752A	Kit, 25" Legs Black W/3" Adj Feet
E8753A	Kit, 25" Legs Black W/Plate Caster
E8754A	Kit, 25" Legs S/S W/3" Adj Feet
E8755A	Kit, 25" Legs S/S W/Plate Casters
E8756A	Kit, Stacking W/6" Adj Feet
E8759A	Kit, Stacking W/Plate Casters
T8097A	Kit, Undershelf
T8026A	Kit, Open Rack Stand
E8765A	Kit, Conversion To Lp
E8766A	Kit, Conversion To Nat

NOTE: When ordering, ALWAYS specify Part #, Model #, Serial #, Voltage/Phase & type of Gas.



GAS CONVECTION OVEN OPERATION MANUAL

EXPLODED VIEW & PARTS LIST

Item	P/N	Description	Qty
1	E8189A	BAFFLE PLATE	1
2	E8138A	MOTOR MOUNT	1
3	M9208A	MOTOR 115V 850/1 725 RPM	1
4	S1195A	BLOWER WHEEL	1
5	E8160A	PANEL, LEFT OUTER	1
6	S6810A	CAM, SWITCH	1
7	M1102A	SWITCH, DOOR	1
8	E8170A	BOTTOM TRIM	1
9	E8178A	SEAL, TOP	1
10	E8177A	SEAL, BOTTOM DOOR	1
11	E8176A	SEAL (BETWEEN LEFT & RIGHT DOOR)	2
12	E8156A	PANEL, TOP OUTER	1
13	E8193A	CONTROL PANEL ASSY.	1
14	M1332A	TIMER, 60 MINUTE	1
15	M0110A	THERMOSTAT, FASTRON G6	1
16	E6895A	BRACKET, BUZZER	1
17	M1352A	SWITCH, ROCKER	1
18	P7200A	TERMINAL BLOCK	1
19	P9600A	PILOT LIGHT GREEN (POWER)	1
20	P1167A	LIGHT, INDICATOR 250V, AMBER	1
21	M2138A	IGNITION MODULE	1
22	M1175A	TIMER, SOLID STATE, 120 VAC, .5-60 SEC (STEAM OPTION ONLY)	1
23	M1335A	AUDIO ALARM	1
24	M1176A	POTENTIOMETER (STEAM OPTION ONLY)	1
25	M1049A	SWITCH, PUSH BUTTON (2 EA - STEAM OPTION ONLY)	1
26	S1311A	KNOB	3
27	U8054A	DECAL BASIC BLUE & GOLD	1
28	E6825A	DOOR, 40 W/WINDOW ASSY	1
29	E6827A	DOOR, 60 W/WINDOW ASSY	1
30	U4198A	DECAL, LEG	1
31	S8768A	CATCH, ROLLER ADJUSTABLE	1
32	S8019A	PLATE, STRIKER	1
33	T3044A	SUPPORT, WIRE RACK	2
34	T3043A	RACK, FULL SIZE	5
35	E6865A	SUPPORT, SIDE RACK	8
36	L5091A	BURNER w/IGNITOR BRACKET	1
37	M2140A	IGNITER 24 V	1
38	R3180A	ORIFICE #48 NAT ONLY	4
	R6756A	ORIFICE 1.25MM LP ONLY	4
39	R8118A	MANIFOLD	1
40	R3161A	CARRY OVER, PILOT ORIFICE #71 (NAT)	1
41	E8187A	BRACKET MANIFOLD	1
42	E8143A	PANEL, FRONT FIREBOX	1
43	M1323X	FLAME SENSOR	1
44	N3010A	ELBOW, 1/2" X 90"	3
45	N5024A	NIPPLE, 1/2" X 8"	1
46	N3009A	UNION, 1/2"	2

Item	P/N	Description	Qty
47	R3164A	VALVE, COMBINATION (NAT.)	1
	R3165A	VALVE, COMBINATION (L.P.)	1
48	N5019A	NIPPLE, 1/2" X 1-1/8" STEEL PIPE	3
49	E8188A	BRACKET, SUPPORT	1
50	P9900A	CLIP JIFFY 1/2"	2
51	E8144A	BOTTOM CHANNEL	6
52	S0420A	THRUST BEARING	4
53	S6819A	ARM, 60 WELDMENT	1
54	S6821A	ARM, 40 WELDMENT	1
55	S6805A	SPROCKET, DOOR	2
56	N7103A	FITTING, NUT S/S COMP 1/4 TUBE (STEAM OPTION ONLY)	2
57	E8778A	BRACKET, MOUNTING (STEAM OPTION ONLY)	1
58	M1114A	SOLENOID VALVE, 1/8 X 1/8 (STEAM OPTION ONLY)	1
59	N3041A	FITTING 1/4 COMP X 1/8 MPT (STEAM OPTION ONLY)	2
60	N5815A	FITTING, 1/4" Tube Sleeve S/S FERRULE (STEAM OPTION ONLY)	2
61	N8788A	STEAM TUBE (STEAM OPTION ONLY)	1
62	N3041A	FITTING, FEM SS COMP 1/4 TUBE TO 1/8 PIPE (STEAM OPTION ONLY)	1
63	N1019A	STEAM INJECTION NOZZLE (STEAM OPTION ONLY)	1
64	N8789A	TUBE, SUPPLY (STEAM OPTION ONLY)	1
65	N8791A	TUBE, VALVE TO OVEN (STEAM OPTION ONLY)	1
66	M1115A	SOLENOID COIL 120/240 V,17/12 W, 50/60Hz (STEAM OPTION ONLY)	1
67	P1144A	SNAP IN LIGHT ASSY 130V/15W	2
68	S6816A	EYE HOOK, SHORT	2
69	S6814A	EYE HOOK, LONG	2
70	S0410A	TURNBUCKLE, 1/4-20	2
71	Q4033A	ROLL PIN .250 X 1.250	2
72	E8125A	BRACKET WELDMENT	1
73	E8159A	PANEL, RIGHT OUTER	1
74	S8159A	PANEL, INSERT CONTROL	1
75	U1043A	NAME PLATE	1
76	M1326A	SWITCH, 4 POSITION ROTARY	1
77	P1900A	CONNECTOR, 1/2" FLEX STRAIGHT	4
78	U3149A	LABEL, WARNING HOT SURFACE (FRENCH)	1
79	U3103A	LABEL, WARNING, HOT SURFACE	1
80	U4197A	DECAL, CAUTION DISCONNECT	1
81	E8790A	WELDMENT, WALLTUBE MOUNT	1
82	E8064K	ADAPTER, VENT (DIRECT VENTING ONLY)	1
83	S0430A	FLANGE BEARING	1
84	L5090A	BURNER	3
85	N5007A	NIPPLE, 1/2" X 2-1/2" STEEL PIPE, BLACK	1
86	M1360A	TRANSFORMER, CLASS 2,120/240V-24V, 40VA	1
87	E8779A	BRACKET, MOUNTING (POTENTIOMETER)	1
88	S6804A	CHAIN, ROLLER #35	2
89	Q2039A	NUT, HEX, LEFT HAND 1/4-20 SS	2
90	Q2016A	NUT, HEX, 1/4-20 SS	2
91	M0120A	PROBE, RTD	1
92	R3002Y	DIRECT VENT	1

NOTE: When ordering, ALWAYS specify Part #, Model #, Serial #, Voltage/Phase & type of Gas.



BAKERS PRIDE LIMITED WARRANTY

WHAT IS COVERED	<p>This warranty covers defects in material and workmanship under normal use, and applies only to the original purchaser providing that:</p> <ul style="list-style-type: none">• The equipment has not been accidentally or intentionally damaged, altered or misused;• The equipment is properly installed, adjusted, operated and maintained in accordance with National and local codes and in accordance with the installation instruction provided with the product;• The serial number rating plate affixed to the equipment has not been defaced or removed.
WHO IS COVERED	<p>This warranty is extended to the original purchaser and applies only to equipment purchased for use in the U.S.A.</p>
COVERAGE PERIOD	<p>Cyclone Convection Ovens: BCO Models: One (1) Year limited parts and labor; (1) Year limited door warranty. GDCO Models: Two (2) Year limited parts and labor; (2) Year limited door warranty. CO11 Models: Two (2) Year limited parts and labor; (5) Year limited door warranty. All Other Products: One (1) Year limited parts and labor. Warranty period begins the date of dealer invoice to customer or ninety (90) days after shipment date from Bakers Pride - whichever comes first.</p>
WARRANTY	<p>This warranty covers on-site labor, parts and reasonable travel time and travel expenses of the authorized service</p>
COVERAGE	<p>Representative up to (100) miles, round trip, and (2) hours travel time. The purchaser, however, shall be responsible for all expenses related to travel, including time, mileage and shipping expenses on smaller counter models that may be carried into a Factory Authorized Service Center, including the following models: PX-14, PX-16, P18, P22S, P24S, PD-4, PDC, WS Series and BK-18.</p>
EXCEPTIONS	<p>All removable parts in Bakers Pride® cooking equipment, including but not limited to: Burners, Grates, Radiants, Stones and Valves, are covered for a period of SIX MONTHS. All Ceramic Baking Decks are covered for a period of THREE MONTHS. The installation of these replacement decks is the responsibility of the purchaser. The extended Cyclone door warranty years 3 through 5 is a parts only warranty and does not include labor, travel, mileage or any other charges.</p>
EXCLUSIONS	<ul style="list-style-type: none">• Negligence or acts of God,• Failures caused by erratic voltages or gas supplies,• Thermostat calibrations after (30) days from equipment installation date,• Unauthorized repair by anyone other than a Bakers Pride Factory Authorized Service Center,• Air and Gas adjustments,• Damage in shipment,• Light bulbs,• Alteration, misuse or improper installation,• Glass doors and door adjustments,• Thermostats and safety valves with broken capillary tubes,• Fuses,• Char-broiler work decks and cutting boards,• Tightening of conveyor chains,• Adjustments to burner flames and cleaning of pilot burners,• Tightening of screws or fasteners,• Accessories — spatulas, forks, steak turners, grate lifters, oven brushes, scrapers, peels. etc.,• Freight — other than normal UPS charges,• Ordinary wear and tear.
INSTALLATION	<p>Leveling and installation of decks as well as proper installation and check out of all new equipment —per appropriate installation and use materials — is the responsibility of the dealer or installer, not the manufacturer.</p>
REPLACEMENT PARTS	<p>Bakers Pride genuine Factory OEM parts receive a (90) day materials warranty effective from the date of installation by a Bakers Pride Factory Authorized Service Center.</p>

This Warranty is in lieu of all other warranties, expressed or implied, and all other obligations or liabilities on the manufacturer's part. Bakers Pride shall in no event be liable for any special, indirect or consequential damages, or in any event for damages in excess of the purchase price of the unit. The repair or replacement of proven defective parts shall constitute a fulfillment of all obligations under the terms of this warranty.



1307 N. Watters Rd, Ste. 180 Allen, Texas 75013
Phone 800.527.2100 | Fax 914.576.0605 | bakerspride.com

Be sure to keep up with new product
announcements and events on social media!

