



OPERATION MANUAL

CYCLONE SERIES FULL-SIZE ELECTRIC CONVECTION OVENS

SERIES: BCO-E & GDCO-E



BUILT BY CRAFTSMEN. TESTED BY TIME®.



ELECTRIC CONVECTION OVEN OPERATION MANUAL

ELECTRIC CONVECTION OVENS

Models:

BCO-E and GDCO-E

⚠ WARNING

FOR YOUR SAFETY: Do not store or use gasoline or other flammable vapors or liquids in the vicinity of this or any other appliance.

⚠ WARNING

California Residents Only
WARNING: This product can expose you to chemicals including chromium which is known to the State of California to cause cancer and birth defects or other reproductive harm. For more information go to www.P65Warnings.ca.gov.

⚠ CAUTION

Improper installation, adjustment, alteration, service or maintenance can cause property damage, injury or death. Read the installation, operating and maintenance instructions thoroughly before installing or servicing this equipment.

⚠ WARNING

Initial heating of oven may generate smoke or fumes and must be done in a well-ventilated area. Overexposure to smoke or fumes may cause nausea or dizziness.

Please retain this manual for future references.

This equipment is design engineered for commercial use only.



BAKERS PRIDE OVEN COMPANY, LLC.

1307 N. Watters Rd., Suite 180
Allen, TX 75013

(800) 527-2100 Phone | (914) 576-0605 Fax | www.bakerspride.com

P/N 8898400 REV B 2/20



TABLE OF CONTENTS

INSTALLATION INSTRUCTIONS	1	FAHRENHEIT OR CELSIUS TEMPERATURE DISPLAY	9
RECEIVING	1	PROGRAMMABLE TIMES	9
SET-UP/MOUNTING	1	PROGRAMMABLE TEMPERATURES	9
INSTALLATION WITH CASTERS	2	PROGRAMMABLE HOLD19	
LOCATION & MINIMUM CLEARANCES	2	PROGRAMMABLE FAN	9
ELECTRICAL CONNECTIONS	3	FLASHING DISPLAY	9
FLUE CONNECTION VENTILATION	3	PROGRAMMING THE OVEN CONTROLLER	10
INITIAL CLEANING	4	CLEANING	11
SYSTEM CHECK – ROTARY CONTROLS	4	SERVICING	12
OPERATING INSTRUCTIONS	4	OPEN RACK ASS'Y INSTRUCTIONS	13
GENERAL INSTRUCTIONS	4	STACKING INSTRUCTIONS	14
OPERATION SEQUENCE FOR ROTARY CONTROLS	4	LEG ASSEMBLY INSTRUCTIONS	14
COOK ONLY	4	HELPFUL HINTS	15
TIMED COOKING	5	TROUBLESHOOTING CHART	15
COOK & HOLD	5	WIRING DIAGRAMS	
STEAM INJECTION (OPTIONAL)	5	SINGLE PHASE 208V/240V WIRING DIAGRAM (DIAL CONTROL)	16
OVEN COOL DOWN	5	THREE PHASE 208V/240V WIRING DIAGRAM (DIAL CONTROL)	16
C&H-3 PUSH BUTTON CONTROL	6	SINGLE PHASE 208V/240V WIRING DIAGRAM (PUSH-BUTTON CONTROL)	17
OPERATING	8	THREE PHASE 208V/240V WIRING DIAGRAM (PUSH-BUTTON CONTROL)	17
OPTIONAL STEAM INJECTION	8	THREE PHASE 230V/400V (EXPORT ONLY) WIRING DIAGRAM (DIAL CONTROL)	18
OVEN COOL DOWN	8	WARRANTY	19
OPERATING NOTES	8		
STARTING A COOK CYCLE	8		
HOLDING TIMERS	8		
DISPLAY DESCRIPTIONS	8		
CONTROLLER FEATURES	9		

INSTALLATION INSTRUCTIONS

Receiving

Read the notice on the outside carton regarding damage in transit. Damage discovered after opening the carton is "CONCEALED DAMAGE." Carrier must be notified immediately to send an inspector and to furnish forms for claims against the carrier.

When the oven arrives, it should consist of:

- A crate or carton containing your new oven (two for a stacked unit).
- A carton containing four 31" legs with mounting hardware (set of four 6" legs is supplied for stacked installations).
- A carton containing a Flue Adapter and a Draft Hood. Optional: for Direct Venting (Not available for European Community Countries).

Set Up / Mounting

NOTICE

This appliance must be installed by competent personnel in accordance with the rules in force.

Your oven will be packed sitting on its bottom. The skid may be left under the oven for convenience in further handling. Unpack carefully, avoiding damage to the Stainless Steel front and/or trim. If concealed damage is found, follow the instructions detailed in Section A (Receiving). Keep the area around the ovens free and clear of combustible materials. Do not store any materials on top of or under any oven. The provision of adequate air supply to your oven for ventilation is essential. As a minimum, observe the clearances detailed in Location Section. Provide adequate ventilation and make up air in accordance with local codes.



INSTALLATION INSTRUCTIONS

Servicing your oven is done through the front control panel and right side access cover. Ensure that these areas are kept unobstructed for easy access.

For a single unit: Refer to Figure 4

- (1) Tilt oven over to left-hand side and attach two 31” legs on the right-hand side with four 3/8-16 bolts and washers. Tighten firmly.
- (2) Using proper lifting equipment, lift up the left-hand side and attach two 31” legs on the left-hand side the same way.

For a stack of two ovens: Refer to Figure 3

- (1) Remove flue from top oven and replace with flue-adaptor supplied in the stacking kit.
- (2) Tilt lower unit over to the left side and position two 6” legs on the right side (one for front and one for back), secure in place by using 4 bolts (3/8-16) per leg. Tighten firmly.
- (3) Using proper lifting equipment, lift up the left side of the unit and attach the other two legs in the same way.
- (4) Using the lifting equipment, raise the top oven to proper height and slide onto top of the bottom oven. Line up sides and front and fasten to each other at the rear of the units by using a mounting bracket supplied in the stacking kit.

To assemble an open rack stand: Refer to Figure 2.

- (1) Loosen 12 bolts (attaching 31” legs) slightly.
- (2) Remove 4 inner bolts, 1 from each of the 4 legs, place top right angle and top left angle underneath and tighten these 4 bolts.
- (3) Insert “Open Rack Shelf” and tighten into place with eight 3/8-16 screws, washers and nuts.
- (4) Position “Rack Supports” and tighten in place using 4 each of flat washers and 5/16-18 hex nuts.

Installation With Casters (Optional):

Four casters (two with wheel brakes) and the mounting hardware are packed and included in the shipment if ordered. Install casters with wheel brakes on the front of the unit. Installation must conform to **UL 197: Electrical Supply Connections for Permanently Connected Appliances**. It requires that permanently connected appliances with casters be provided with a means for securing the appliance to the building structure to limit the movement of the appliance.

Oven Restraint: When casters are installed on either a single or double unit, a fixed restraint must be used to limit the movement of the appliance without depending on or transmitting stress to the electrical conduit. The restraint (a heavy-gauge cable) should be attached to the rear legs of the oven on which casters are mounted. If disconnection of the restraint is necessary, the restraint must be reconnected after the oven has been repositioned in its permanent location. The appliance shall be installed using flexible conduit.

Location And Minimum Clearances:

Move the oven to its final location keeping the minimum clearance from the back of the oven to the wall. This clearance is necessary for safe operation and to provide proper air flow.

Minimum Clearances from Combustible and Non-combustible Construction	
	Under Ventilation Hood
RIGHT WALL	1”
LEFT WALL	1”
REAR WALL	3”

⚠ CAUTION

Suitable for installation on combustible floor when installed with legs or casters provided.

⚠ CAUTION

Do not set the oven with its back flat against the wall. It will not operate properly unless there is at least three inches breathing space behind the oven.

NOTICE

Local codes regarding installation vary greatly from one area to another. The National Fire Protection Association, Inc., states in its NFPA 96 latest edition that local codes are “authority having jurisdiction” when it comes to requirements for installation of equipment. Therefore, installations should comply with all local codes.



ELECTRIC CONVECTION OVEN OPERATION MANUAL

INSTALLATION INSTRUCTIONS

Electrical Connection:

Install according to the spacing requirements listed in the installation section of this manual. We strongly recommend having a competent professional install this equipment. A licensed electrician should make the electrical connections and connect power to the unit. Local codes should always be used when connecting these units to electrical power. In the absence of local codes, use the latest version of the National Electrical Code.

NOTICE

Note: For supply connections use No. 6 AWG wires suitable for at least 90°C.

The oven, when installed, must be electrically grounded in accordance with local codes and/or the latest edition of the National Electrical Code ANSI/NFPA No. 70 in the USA (Canadian Electrical Code CSA Standard C22.1, Part 1 in Canada).

In Europe, the appliance must be connected by an earthen cable to all other units in the complete installation and, thence, to an independent earth connection in compliance with EN 60335-1 and/or local codes.

Electrical power is to be supplied to the oven(s) by means of hard wiring, which is to be performed by a qualified licensed electrician.

- Adequate means must be provided to limit the movement of the appliance without depending on or transmitting stress to the electrical conduit.
- The location(s) where restraining means are to be attached to the appliance shall be specified.
- The appliance shall be installed using flexible conduit.

BCO-E, GDCO-E											
Model	KW	Voltage	Phase	Amps				Motor-50hz		Motor-60hz	
				Line 1	Line 2	Line 3	N	RPM (Low)	RPM (High)	RPM (Low)	RPM (High)
BCO-E, GDCO-E	10.5	208	1	48	48	-	-	725	1425	850	1725
	10.5	208	3	30	30	28	-	725	1425	850	1725
	10.5	220-240	1	44	44	-	-	725	1425	850	1725
	10.5	220-240	3	26	26	24	-	725	1425	850	1725

Each oven requires separate electrical connections

Normal factory connections are made for 208 V.A.C. or 208/240 V.A.C., 60 Hz.

This unit is provided with a permanently lubricated electric motor. A wiring diagram may be found on the back of the service panel on the right-hand side and also in this manual.

Flue Connection Ventilation:

Installation under ventilation hood (standard):

Local inspectors and ventilation specialists should be consulted so that the design and the installation of the hood conform to local/municipal codes. In the U.K., follow ventilation requirements as detailed in B.S. 5440.

If the flue runs directly to the free air outside the building, use a wind deflector or a UL listed vent cap at the end of the pipe. Termination of the vent must be at least two feet above the highest part of the roof within ten feet. REF: AGACATALOG NO. Xh0474.

NOTICE

Do not put a damper in the flue and do not connect a blower directly TO THE FLUE.



INSTALLATION INSTRUCTIONS

Initial Cleaning:

Always clean equipment thoroughly before first use. Clean the protective oil from the metal parts and interior of baking chamber with a solution of washing soda or the other grease dissolving material.

System Check- Rotary Control (Standard):

- (1) Open the oven door.
- (2) Turn Selector Switch to "HI." The green indicator light near Selector Switch and oven light will illuminate.
- (3) Close the door. Oven lights will go off and fan will run. Make sure fan is rotating clockwise looking from front.
- (4) Press Oven Light switch. Oven light will go on and will go off as switch is released.
- (5) Turn the thermostat knob. The amber indicator light near the thermostat will illuminate and the heating elements will come on.
- (6) Turn the timer knob past 10 minutes and back to 2 minutes. At the end of 2 minutes the buzzer will sound. Reset by turning to "0." All settings below 10 minutes require turning past 10 minutes and then back to the time required.

NOTICE

With the doors closed, the power switch "on" and the selector switch is in any position other than "0", the oven will start heating as soon as the set temperature is higher than the oven temperature.

Thermostat indicator light goes out when oven reaches set temperature and comes on when oven is heating up.

In the event of power failure, the oven will not operate.

- (7) Open the oven doors. Oven lights will go on and elements and fan will go off.
- (8) Turn Selector Switch to "Cool Down" position. The fan will run to cool down the oven.
- (9) Turn Selector Switch to "0" position.
- (10) Close the oven doors.

Programming Menus: See Operating/Programming Instruction Booklet for Programmable Oven Control with Bakers Pride Software for Cyclone Series Convection Ovens supplied with this option.

OPERATING INSTRUCTIONS

General Instructions:

- (1) This equipment has an Electronic Temperature Control.
- (2) Due to increased efficiency of this oven, the temperature of standard recipes may be reduced 50°F (30°C).
- (3) Always load each shelf evenly. Space pans away from each other and from sides and back of oven to allow maximum air flow between them.
- (4) Large tempered glass windows and interior lights allow a close check on the product making it unnecessary to frequently open the doors. Products cook faster in a convection oven as compared to a conventional oven. Depending on the product and the type of pans used, time saving may run from 20 percent to as high as 50 percent.

Operation Sequence Rotary Control:

Cook only rotary control:

- (1) Close the oven doors.
- (2) Turn Selector Switch to "HI" or "LO" position. The indicator light near the Selector Switch will be illuminated.
- (3) Turn the thermostat knob to the desired cooking temperature.
- (4) Upon reaching the set temperature, the indicator light near the thermostat will go out.
- (5) Load the oven with product to be cooked.
- (6) Remove the product from the oven when done.



OPERATING INSTRUCTIONS

Timed cooking rotary control:

- (1) Close the oven doors.
- (2) Turn Selector Switch to “HI” or “LO” position. The indicator light near the Selector Switch will be illuminated.
- (3) Turn the thermostat knob to the desired cooking temperature.
- (4) Upon reaching the set temperature, the indicator light near the thermostat will go out.
- (5) Load the oven with product to be cooked.
- (6) Turn the timer knob to the desired bake time and timer will start counting down.
- (7) When timer reaches zero, a buzzer will sound.
- (8) Turn the timer knob to “O” position.
- (9) Remove the product from the oven.

NOTICE

Timer does not control the oven.

Cook and Hold Rotary Control:

- (1) Close the oven doors.
- (2) Turn Selector Switch to “HI” or “LO” position. The indicator light near the Selector Switch will be illuminated.
- (3) Turn the thermostat knob to the desired cooking temperature.
- (4) Upon reaching the set temperature, the indicator light near the thermostat will go out.
- (5) Load the oven with product to be cooked.
- (6) Turn the timer knob to the desired bake time and timer will start counting down.
- (7) When timer reaches zero, a buzzer will sound.
- (8) Turn the Timer knob to “O” position.
- (9) Turn the thermostat knob to the desired hold temperature.
- (10) Remove the product from the oven when done.

Optional steam injection Rotary control:

The solenoid valve for steam injection is mounted behind the service panel on the right-hand side of the unit. The electronic timer is preset at the factory. A 1/4” copper tubing is provided on the Solenoid Valve for water hookup with a compression fitting. After the water hookup is made, make sure that there are no leaks. For steam injection, press the Steam switch momentarily.

NOTICE

Do not use steam injection at temperatures below 275°F (135°C).

Oven cool down Rotary control:

To cool down the oven to a lower desired temperature, follow the steps detailed below.

- (1) Open the oven doors.
- (2) Turn Selector Switch to “oven cool down” position. Fan will now operate and cool down the oven.
- (3) When the oven has cooled down to the desired temperature, turn the Selector Switch to “O” position. Close oven doors.

OPERATING INSTRUCTIONS

Operating/Programming Instructions -
**Cook & Hold-3 Plus™ Controller (For Convection
 Ovens: C011-G, C011-E, COCE, GDCO-G & GDCO-E)**

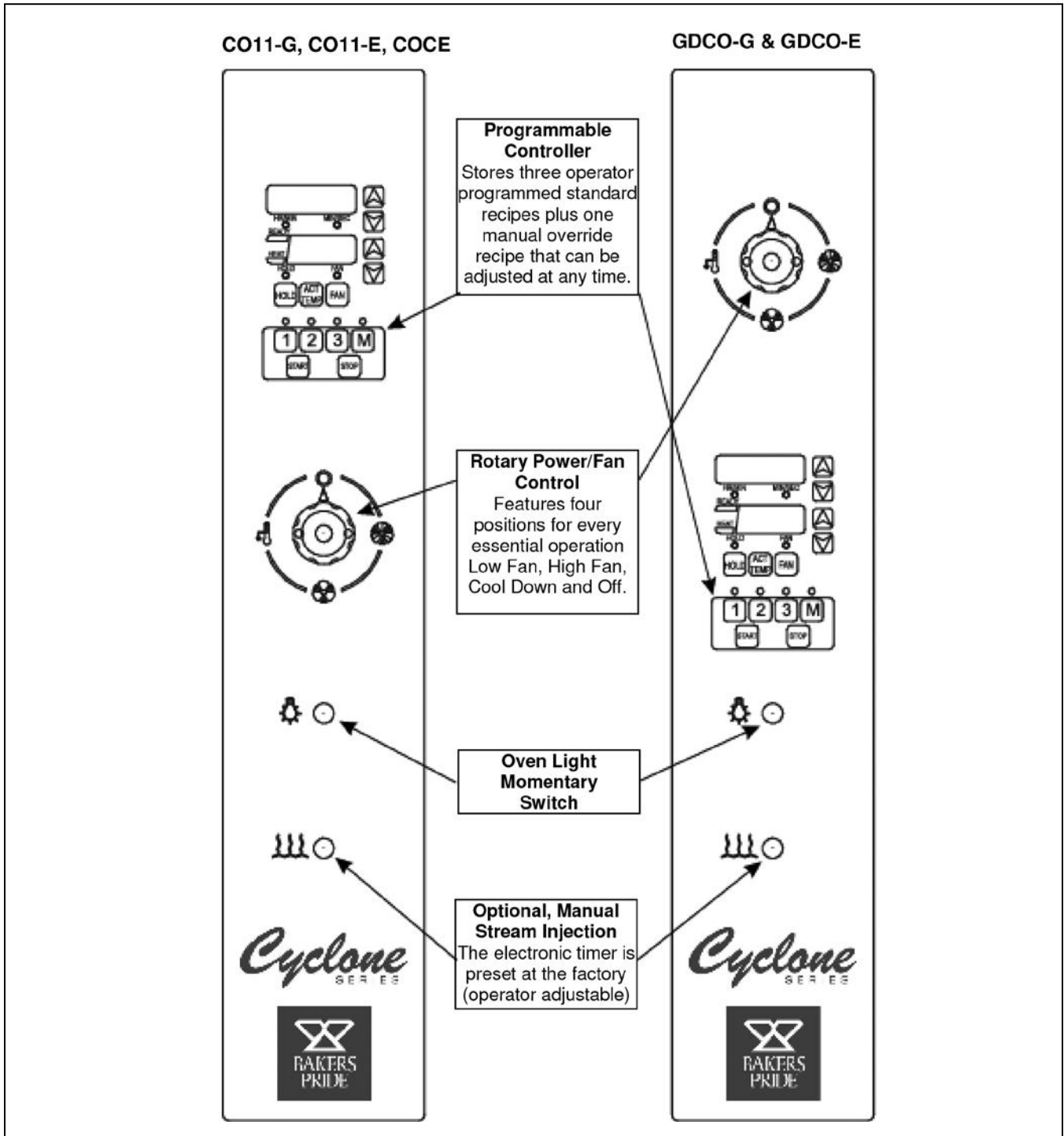

OPERATING INSTRUCTIONS

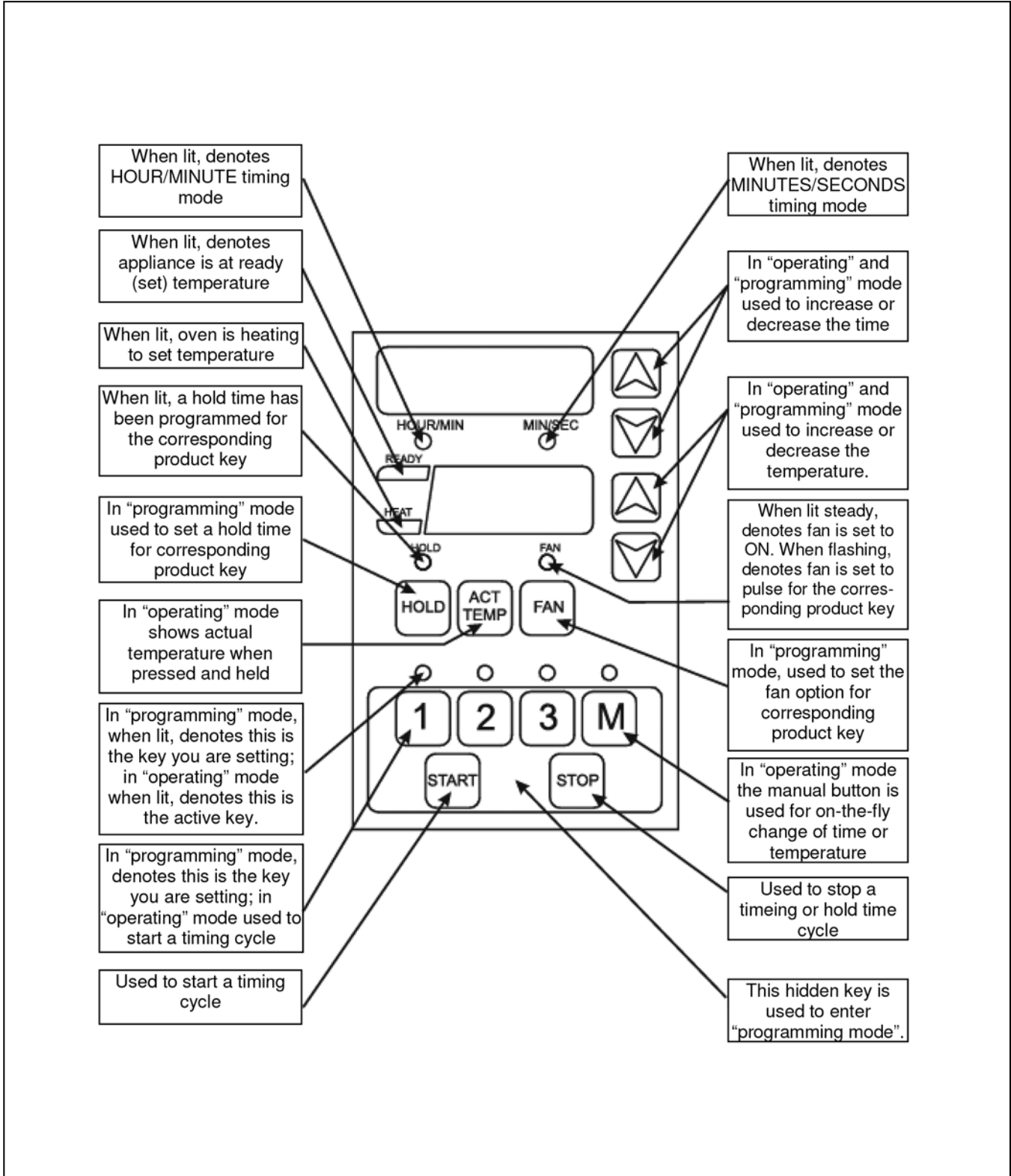



OPERATING INSTRUCTIONS

Operating Instructions

There are 3 programmable times & temperatures, and 1 manual override time & temperature setting. The timing range of all keys is from: 01 second to 99 hours (automatically switches from min/sec. to hour/min). Each key is also programmable for one hold time and a two-position fan (on/pulse).

In normal operating mode, the READY LIGHT (LED) will illuminate when the oven temperature is +20°F of set temperature. The HEAT LIGHT (LED) will illuminate when actual temperature is below set temperature and the unit is calling for heat.

Once set and actual temperatures are equal, key 1, 2, 3 or M may be pressed. The light above the corresponding key will be lit. Pressing the START key will begin a flex time countdown (time is compensating) depending on temperature.

Optional Steam Injection

The solenoid valve for steam injection is mounted behind the service panel on the right-hand side of the unit on COC-E and on back of the unit on CO11 -E/G. The electronic timer is pre-set at the factory and may be adjusted by operator if required for shorter or longer steam burst. For steam injection, press the steam injection switch.

Oven Cool Down

To cool down the oven to a lower desired temperature, follow the steps detailed below: Open the oven door(s). Turn selector switch to “Oven Cool Down” position. Fan will now operate and cool down the oven. When the oven has cooled to the desired temperature, turn the selector switch to the “0” position.

Operating Notes

When the oven is turned on it will automatically preheat to set temperature if the door is closed. If the door is opened while program is running, the cook cycle will pause and the display will flash. When the door is closed, the display will return to the count down from where it was paused.

Starting A Cook Cycle

 To start a cook cycle, simply turn selector switch to LO or HI position and press the product key for the product you wish to cook. If the product key is programmed, the correct cooking time will be displayed 12:00 (example). Press the START key and the time will immediately start to count down in minutes and seconds. If :00 is displayed immediately and the unit starts to signal, the key being operated is not programmed. If correctly programmed, it will count down to :00. When zero is reached, the light above the product key will be flashing, the controller will emit an audible alarm and immediately begin counting up (if programmed for a hold time).

 Cancel this alarm by pressing the stop key; controller will continue to count up.

Holding Timers

If the unit is programmed with a holding time, the holding time will automatically start counting upon expiration of the cooking cycle. When there is an active hold time, the HOLD indicator will be lit and the light above the product key with the hold time will be flashing.

To cancel, press the  key.

Display Descriptions

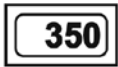
 The unit is in the Operating Mode. The actual temperature is shown in the display and is within 20 degrees of the programmed temperature.

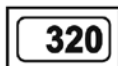
 The unit is in the Operating Mode. The actual temperature will flash in the display and is more than 20 degrees below the programmed temperature range.

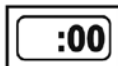
 The unit is in the Operating Mode. The flashing display signifies a cook cycle has just been completed.

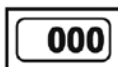
 The unit is in the Operating Mode. With three zeros displayed, the probe has failed, or the appliance has gone beyond operating temperature. Shut the appliance OFF immediately and call a technician.

OPERATING INSTRUCTIONS

Controller Features

Fahrenheit or Celsius Temperature Display

The operator is allowed to configure the controller to display the temperature in degrees Fahrenheit or Celsius from the jumper on the back of the circuit board (J3). By default, the unit is shipped from the factory in Fahrenheit (J3 not shorted), unless otherwise specified by the customer. For Celsius display, power unit down, remove jumper from Pin 1 and short both pins. When power is re-applied, the controller will be in Celsius operation.

Programmable Times

The operator will have the ability to program the cook times for each product key. The controller is programmable in minutes (up to 59) and seconds (up to 59), then hours (up to 99).

Programmable Temperatures

The operator will be able to program cook temperatures for each product key. The valid temperature range is 150 to 550°F (66 to 288°C).

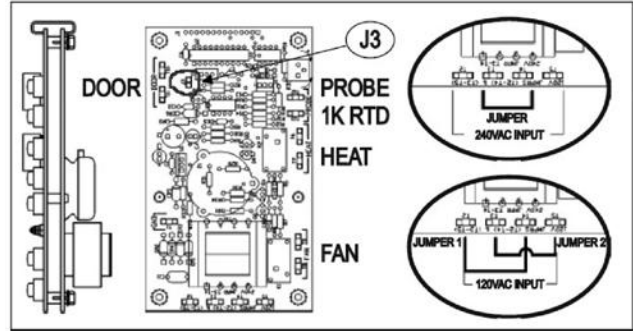

Programmable Hold

The operator will be able to program each product key for a counting hold time and temperature (140 to 200°F/60 to 94°C) or disable the hold mode.
 HOLD LIGHT (LED) ON = hold mode enabled
 HOLD LIGHT (LED) OFF = hold mode disabled

Programmable Fan

The operator will be able to program each product key for one of two fan modes.
 FAN LIGHT (LED) ON = Fan always ON
 FAN LIGHT (LED) Flashing = Fan pulsed

Flashing Display

The temperature display will flash after every product key is pressed. The display will continue to flash until the actual temperature is within 20° of set temperature.



ELECTRIC CONVECTION OVEN OPERATION MANUAL









OPERATING INSTRUCTIONS

Programming the Oven Controller

The following steps are needed to enter and program each of the product keys. Please note that you must follow each of the steps below for each product key.

NOTICE

The manual “M” key allows you to temporarily change the set temperature & time and will reset to the original programming parameters after you are done cooking. This key is programmed the same as keys 1, 2 & 3 except that programming mode does not have to be entered to do it. However, you can still manually program the controller while in programming mode.

		ACTION	RESULT
		Press the product key you want to program.	The corresponding LED will light above the selected product key.
		Enter the programming mode by pressing and holding the area between the START and STOP keys until the light above the product key starts flashing (approx. 3 seconds).	You have successfully entered the programming mode.
		To set the cooking time, press the up and down arrow key to the right of the display.	The longer you press the key, the faster the display will change.
		To set the cooking temperature, press the up and down arrow key to the right of the temperature display.	The longer you press the key, the faster the display will change.
		To select the hold feature and set the holding temperature, press and hold the HOLD key, then use the up or down arrow to the right of the temperature display to select your holding temperature.	This will activate the holding feature and set the holding temperature. NOTE: The light above the HOLD key will be on if you have set the hold feature correctly.
		To select the fan operation, press the FAN key until the mode you want is displayed.	1. The light above the FAN key is on, the fan will be ON when door is closed. 2. The light above the FAN key is flashing, the fan will ONLY be ON when the heat goes ON.
		To exit the programming mode, press the space between the START and STOP keys.	The product key light will be on steady, and the program will be saved.

Portions of this instruction manual pertaining to the ch-100 controller are reprinted with the permission of Food Automation-Service Techniques, Inc. (Fast).
© 2001 Bakers Pride Oven Co., Inc. All rights reserved.



OPERATING INSTRUCTIONS

Cleaning

Always clean equipment thoroughly before first use.
Clean unit daily.

⚠ WARNING

To avoid any injury, turn the power switch off at the fuse disconnect switch/circuit breaker or unplug the unit from the power source and allow to cool completely before performing any maintenance or cleaning.

⚠ WARNING

Unit is not waterproof. To avoid electrical shock or personal injury, DO NOT submerge in water. DO NOT operate if it has been submerged in water. DO NOT clean the unit with a water jet. DO NOT steam clean or use excessive water on the unit.

⚠ CAUTION

Use mild detergent or soap solution for best results. Abrasive cleaners could scratch the finish of your unit, marring its appearance and making it susceptible to dirt accumulation. DO NOT use abrasive cleaners or cleaners/sanitizers containing chlorine, iodine, ammonia or bromine chemicals as these will deteriorate the stainless steel and glass material and shorten the life of the unit. Use nylon scouring pads. DO NOT use steel wool.

Oven Interior:

Clean The Racks And Rack Support Guides:

Open the doors and remove all wire racks and rack support guides. Take them to the sink and thoroughly clean in warm water with mild detergent or soap. Use a nylon scouring pad or stiff nylon brush.

DO NOT USE STEEL WOOL.

Clean The Stainless Steel Interior:

Baked on splatter, oil, grease or discoloration on the stainless steel inside of the oven may be removed with stainless steel cleaner, or any other similar cleaning agent. NEVER use vinegar or any corrosive cleaner. Use only cleaners approved for stainless steel. NEVER use cleaning solvents with a hydrocarbon base. NEVER use a wire brush, steel or abrasive scouring pads, scraper, file or other steel tools. NOTE: ALWAYS RUB THE STAINLESS STEEL ALONG THE GRAINS.

Clean The Blower Wheel:

To clean the blower wheel, remove and immerse in ammoniated water for 20 to 25 minutes. Then, scrub it off with a small, stiff brush. The same procedure can be followed for wire racks and rack supports. To remove the blower wheel, loosen the set screws (2) on the hub of the blower wheel and tighten the 3/8" wheel puller bolt (supplied) in center of hub (See Fig. 1).

Clean The Porcelain Interior:

Porcelain enamel interiors are designed to be as maintenance free as possible. However, for best results, the oven should be cleaned regularly. Enameled interiors can be easily cleaned with oven cleaners. Keep cleaning fluids away from electrical wires, light sockets, switches and control panel.

Oven Exterior:

Clean The Exterior Stainless Steel:

To remove normal dirt or product residue from stainless steel, use ordinary soap and water (with or without detergent) applied with a sponge or cloth. Dry thoroughly with a clean cloth. Never use vinegar or corrosive cleaner. Do not use chlorine based cleaners.

To remove grease and food splatter or condensed vapors that have baked on the equipment, apply cleaners to a damp cloth or sponge and rub cleanser on the metal in the direction of the polished lines on the metal. Rubbing cleanser as gently as possible in the direction of the polished lines will not mar the finish of the stainless steel. To remove discoloration, use a non-abrasive cleaner. NEVER use a wire brush, steel or abrasive scouring pads, scraper, file or other steel tools. Never rub with a circular motion.

OPERATING INSTRUCTIONS

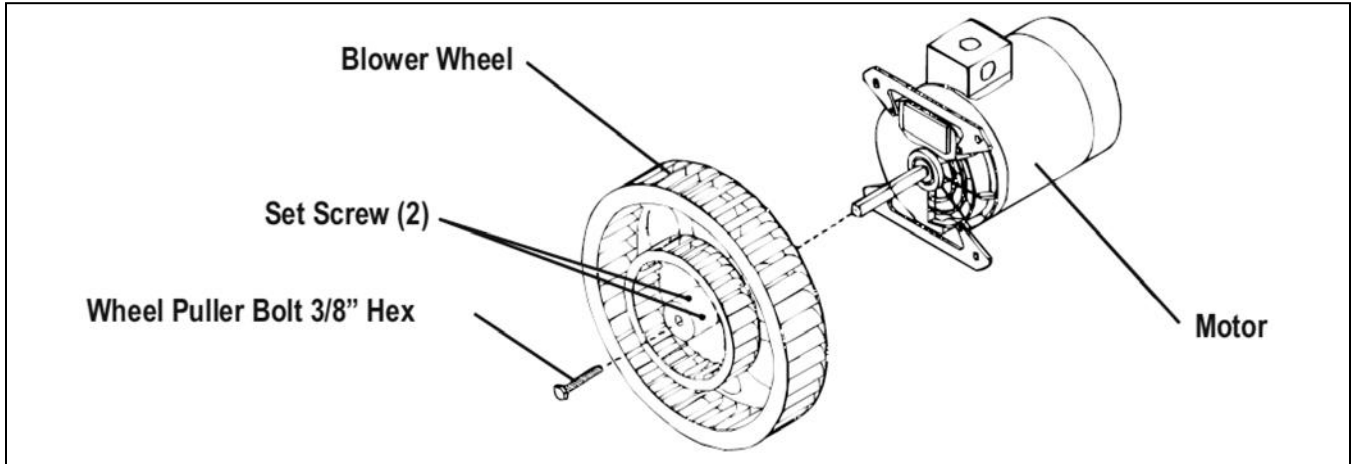

Figure 1: Cleaning The Blower Wheel

Servicing:

NOTICE

This appliance must be serviced by an authorized service agent.

- (1) Power supply to the unit must be disconnected before any service is performed.
- (2) Most of the service on the unit can be performed from the front and/or control panel side.
- (3) For proper servicing, access to the control panel side of the unit will be required.
- (4) It will be necessary to have access to the back of the oven for service needs related to the electric power supply.
- (5) A system wiring diagram is provided in this manual and on the back of the service panel on the right side of the oven.

- (6) All servicing should be performed by a factory-authorized technician only.
- (7) For proper maintenance and repairs, call the factory toll free (800-431-2745) for an authorized service agency in your area.

⚠ WARNING

RISK OF FIRE. When stacked two high maximum, use stacking kit part # E3771A only.

⚠ CAUTION

This product, when stacked, has more than one power-supply connection point. Disconnect all power supplies before servicing.

OPERATING INSTRUCTIONS

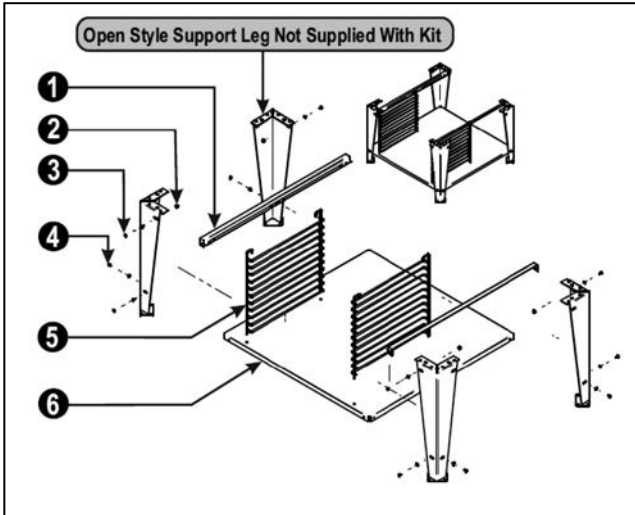

Figure 2: Open Rack Stand Assembly Instructions:
BCO-E & GDCO-E

Assembly Instruction

1. Place undershelf (6) between legs & secure with 1 1/4-20 UNC screws (4), flat washers (3) & 2 locknuts (2). The holes for mounting the wire racks should be toward the front of the oven.
2. Place open rack supports (1) between legs & secure with 1/4-20 UNC screws (4), flat washers (3) & locknuts (2).
3. Slide wire rack supports (5) into position using the holes in the undershelf (6) as a guide.

Item	P/N	Description	Quan
1	21818232	Support, Open Rack	2
2	770504	Lock Nut 1/4-20	12
3	8519600	Washer, Flat 1/4"	12
4	8208200	Screw, 1/4-20 x 3/4"	12
5	21816807	Support, Wire Rack	2
6	21818220	Undershelf, Gas Oven	1

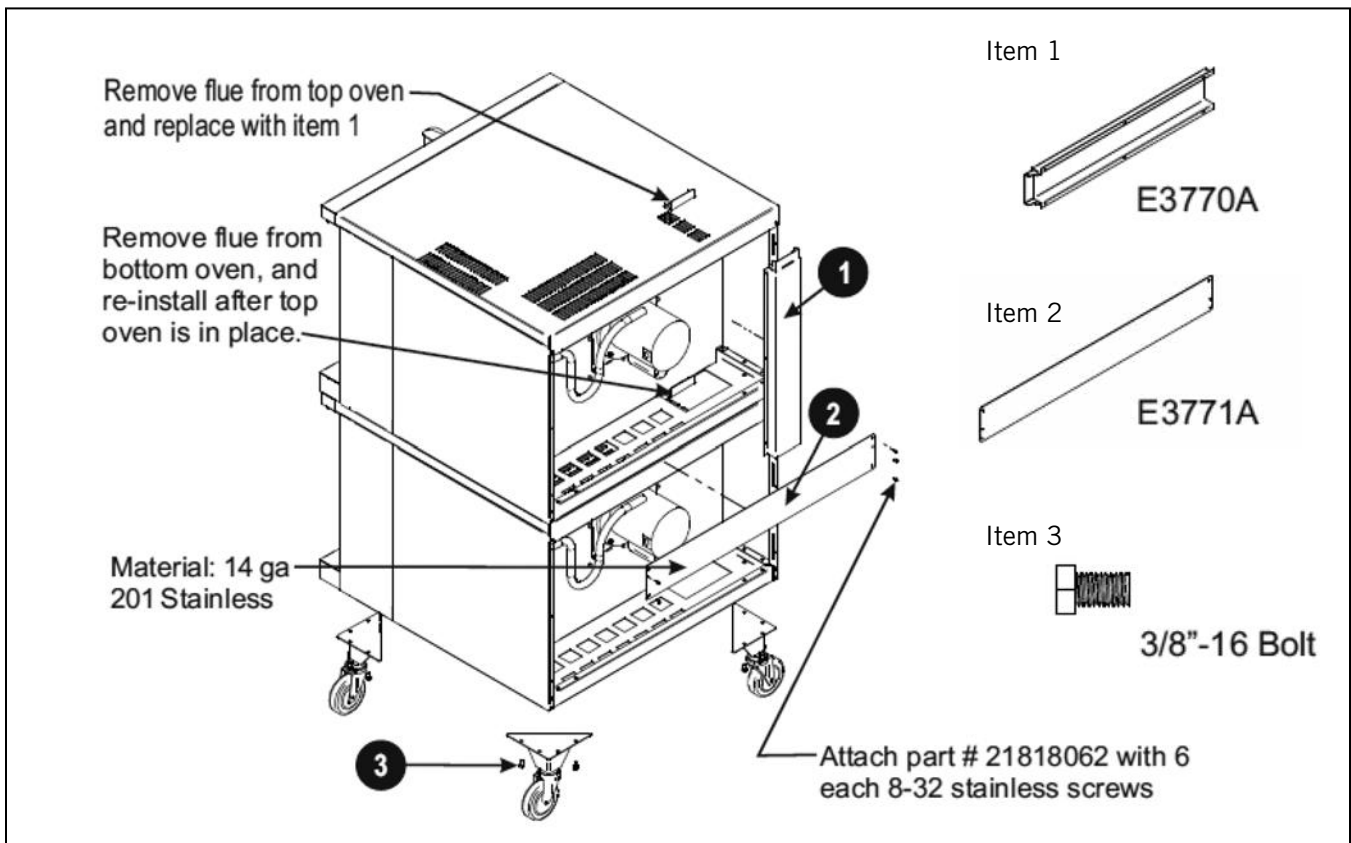

Figure 3: Stacking Instructions For: BCO-E & GDCO-E Convection Ovens

OPERATING INSTRUCTIONS

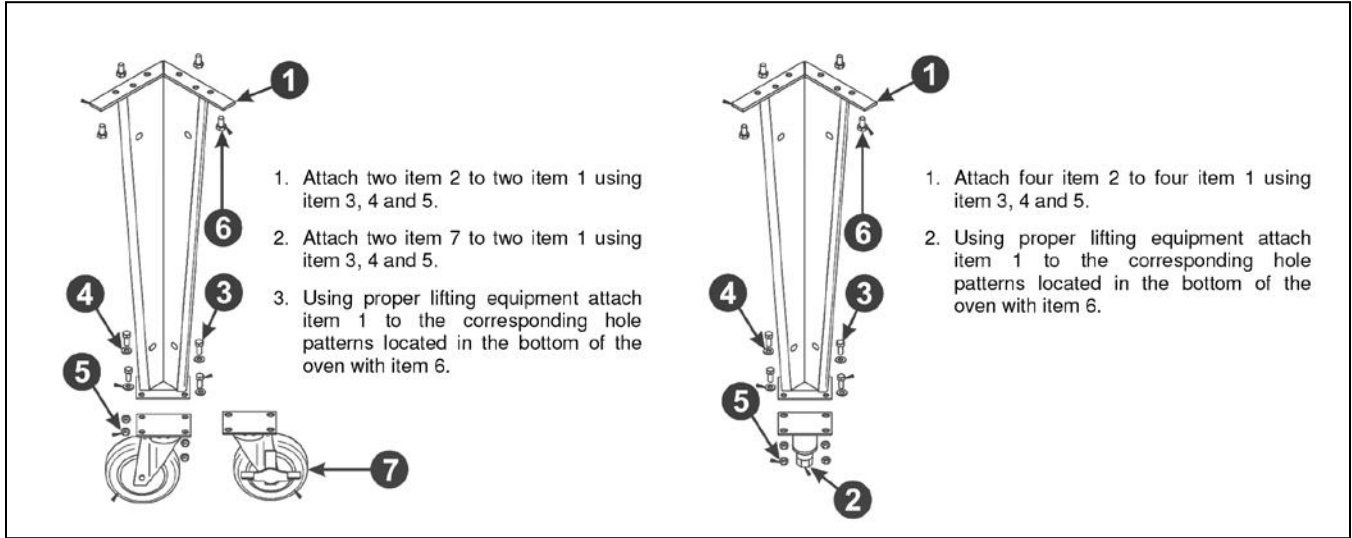

Figure 4: Leg Assembly Instructions - Model: BCO-E & GDCO-E

Item	P/N	Description
1	21796810	Weldment, Oven Leg
2	8633102	Caster, 5" Swivel W/Top Plate
3	8227700	Hex Hd 5/16-18 X 3/4 Bolt #5 Zn
4	8509300	Washer, Flat SAE, 5/16
5	8435000	Hex-nut 5/16-18
6	82447-00	Hex Hd. 3/8-16 X .750 #5
7	8633101	Caster, 5" Swivel W/Plate & Brake

Item	P/N	Description
1	21796810	Weldment, Oven Leg
2	8633515	Foot Insert, Adjustable
3	8227700	Hex Hd 5/16-18 X 3/4 Bolt #5 Zn
4	8509300	Washer, Flat SAE, 5/16
5	8435000	Hex-nut 5/16-18
6	82447-00	Hex Hd. 3/8-16 X .750 #5



ELECTRIC CONVECTION OVEN OPERATION MANUAL

OPERATING INSTRUCTIONS

HELPFUL HINTS		
PROBLEM	CAUSE	SOLUTION
Food browns unevenly	Improper heating temperature.	Preheat until desired temperature is reached.
	Aluminum foil on rack or oven bottom.	Remove foil.
	Several pans crowded together.	Center pans on racks, or leave more space between all pans and oven walls.
	Baking pans too large.	Use smaller pan.
	Baking pan dark or glass.	Lower oven temperature 25°F (-3.8°C) for this type of pan.
	Temperature too low	Increase temperature
Time too short	Increase bake time	
Food dries before browning	Oven temperature too high	Lower oven temperature
	Oven door opened too frequently	Check food a minimum number of times.
Cookies too brown	Oven temperature too high	Lower oven temperature
	Dark cookie sheet	Use light, shiny cookie sheet.
	Pans too deep	Use a cookie sheet (not a baking pan).
Cookies too flat	Hot cookie sheet	Allow cookie sheet to cool between batches.
	Fan is set on high	Speed Set fan to low speed
Cake too brown on bottom or crust forms on bottom	Oven temperature too high.	Lower temperature; if using glass or dark pan, lower 25°F (-3.8°C)
Cakes have light outer color	Thermostat set too low.	Raise temperature
Cake settles slightly in the center.	Bake time too short or bake temperature too low.	Bake longer or raise oven temperature slightly. Do not open doors to oven for long periods.
Cake ripples	Overloading pans or batter is too thin	Reduce pan loads. Thicken batter.
Cakes are too coarse	Thermostat set too high.	Lower oven temperature.
Pies have uneven color	Too many pies per rack.	Reduce number of pies per rack or eliminate use of bake pans.
Cupcakes crack on top	Thermostat set too high.	Lower oven temperature.
Meats are browned & not done in the center	Thermostat set too high.	Lower oven temperature and roast longer.
Meats are well done and not browned	Thermostat set too low.	Raise temperature. Limit amount of moisture.
Meats develop hard crust	Thermostat set too high.	Reduce temperature or place pan of water in oven
	Fan is set on high speed	Set fan to low speed

TROUBLESHOOTING CHART		
PROBLEM	CAUSE	SOLUTION
No heat	Oven has no electrical power	Check electrical supply.
	Power switch on control panel is off.	Set the control panel to COOK or OVEN ON.
	Doors are open.	Close doors.
Oven does not come to ready.	The oven has not reached preheat temperature.	Wait for oven to reach preheat temperature.
	Internal problem with main temperature control.	Call Bakers Pride factory authorized service center
Convection fan does not run.	Oven has no electrical power.	Check electrical supply.
	Circuit breaker tripped.	Reset the breaker.
	Doors are open	Close doors.
	Door switch	Call Bakers Pride factory authorized service center

OPERATING INSTRUCTIONS

Wiring Diagrams

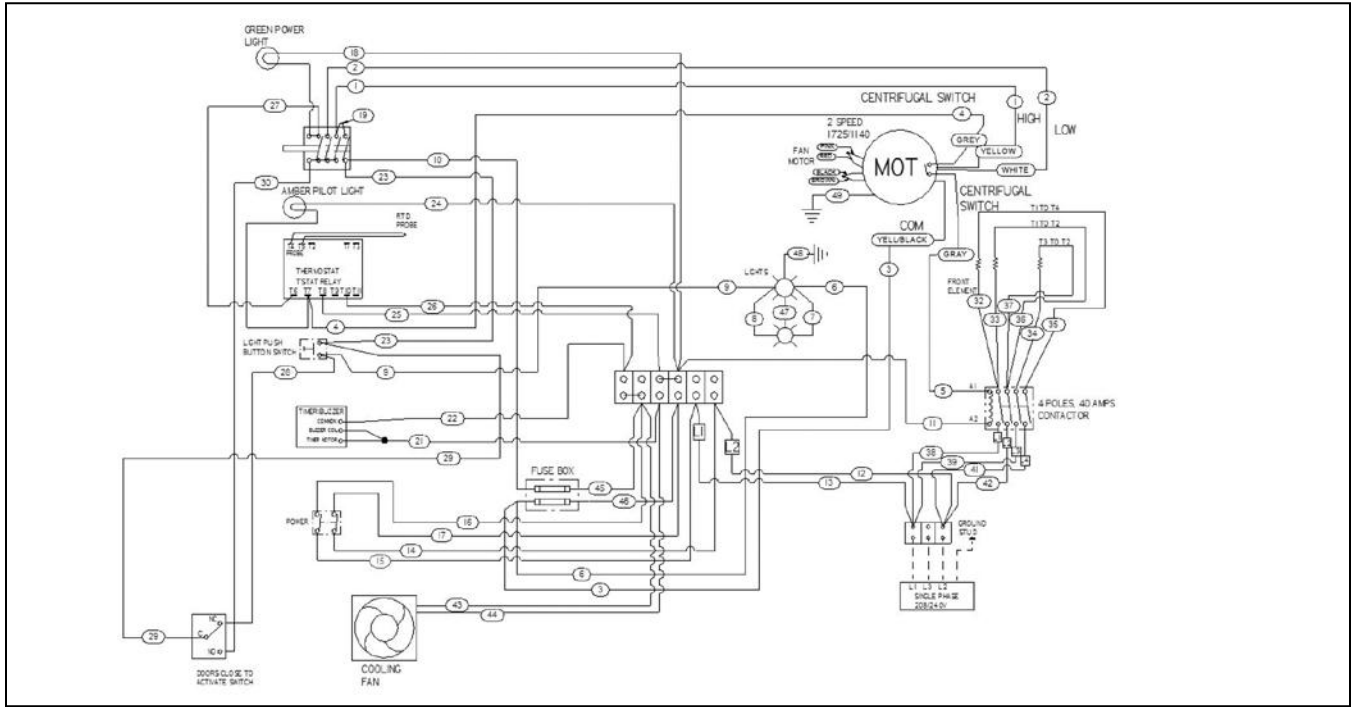

Wiring Diagram – BCO-E & GDCO-E 208V/240V, 1 Phase (Dial Control)

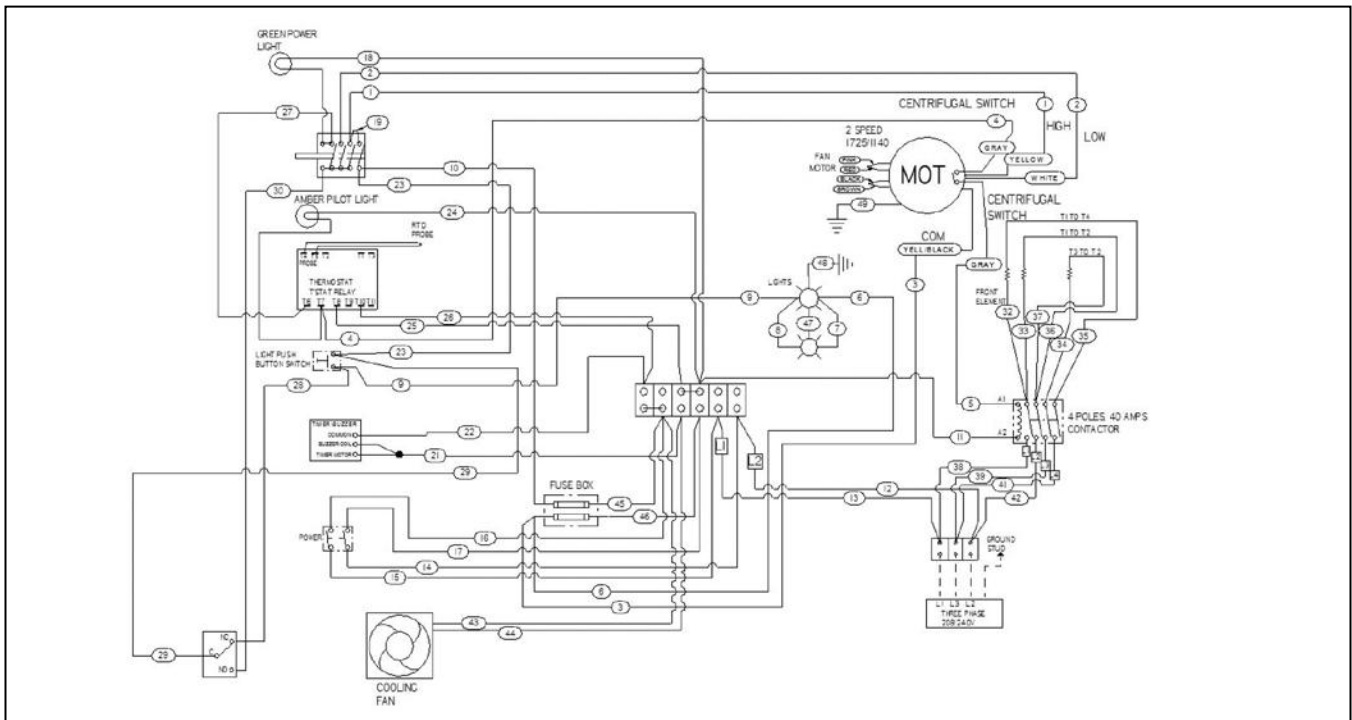

Wiring Diagram – BCO-E & GDCO-E 208V/240V, 3 Phase (Dial Control)

OPERATING INSTRUCTIONS

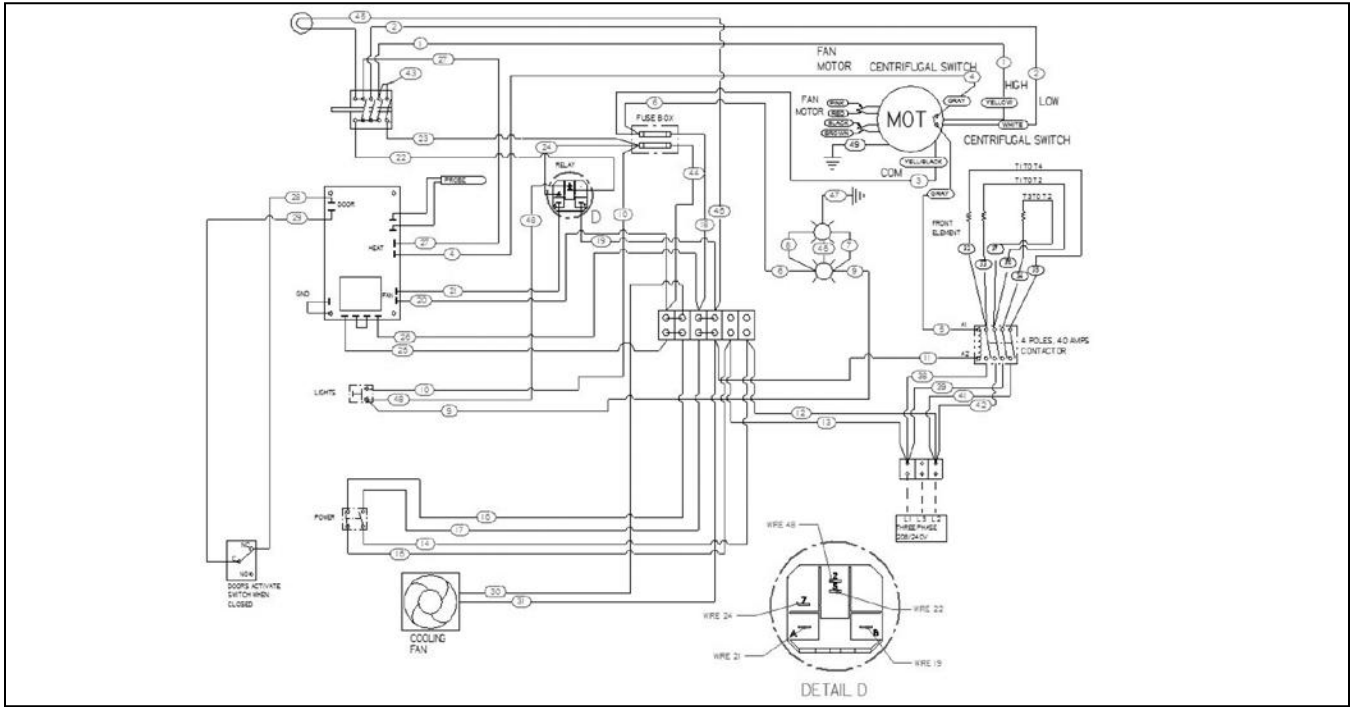

Wiring Diagram – GDCO-E 208V/240V, 1 Phase (Push-Button Control)

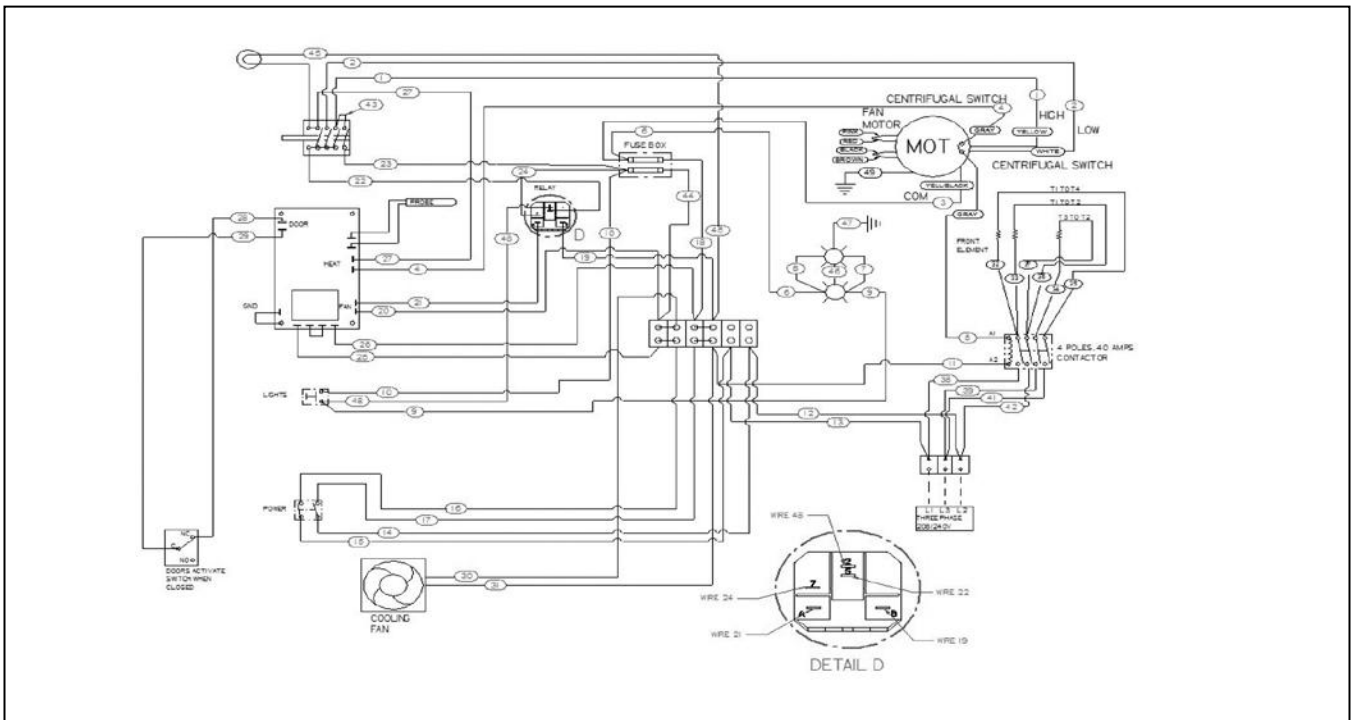

Wiring Diagram – GDCO-E 208V/240V, 3 Phase (Push-Button Control)

OPERATING INSTRUCTIONS

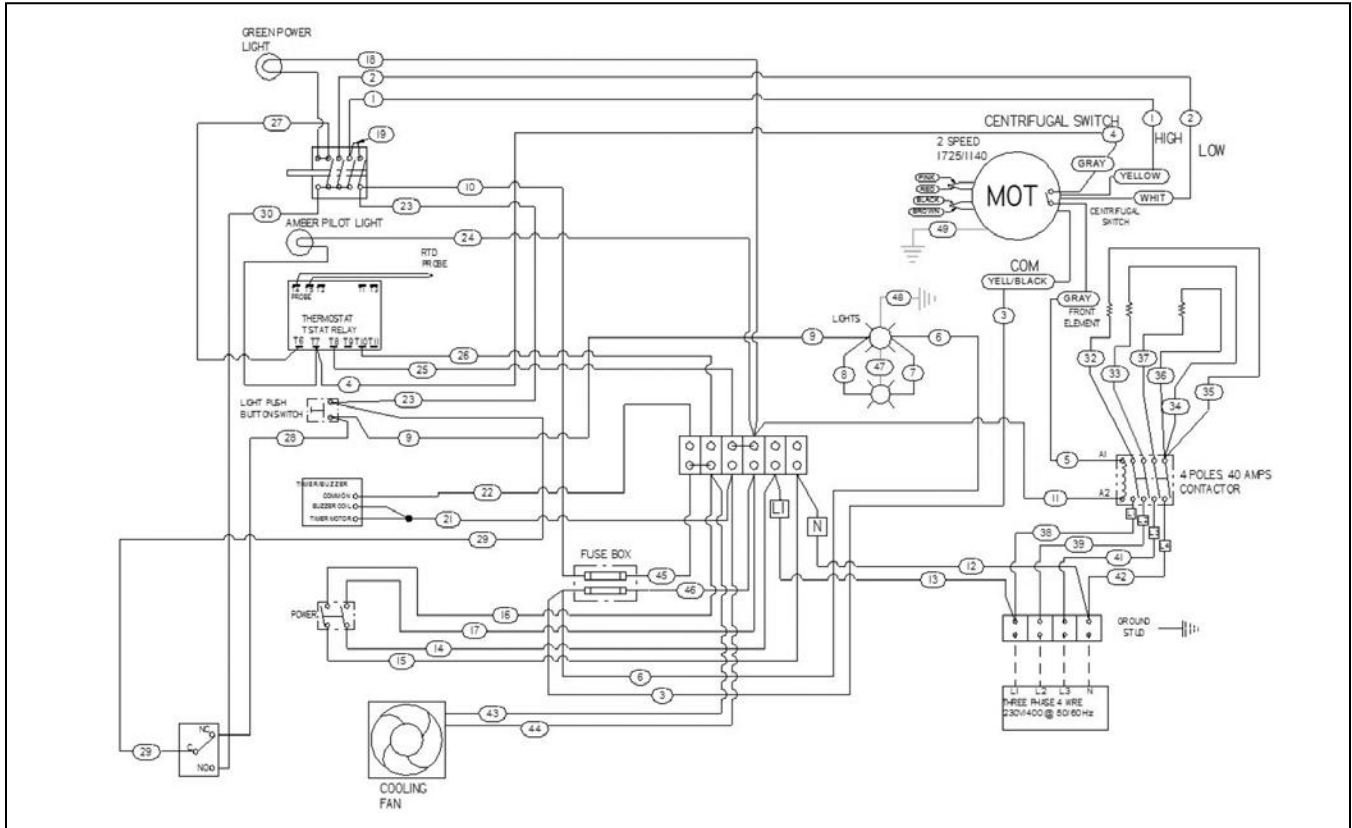

Wiring Diagram–BCO-E & GDCO-E 230V/400V, 3 Phase, 4 Wire (Dial Control) - EXPORT

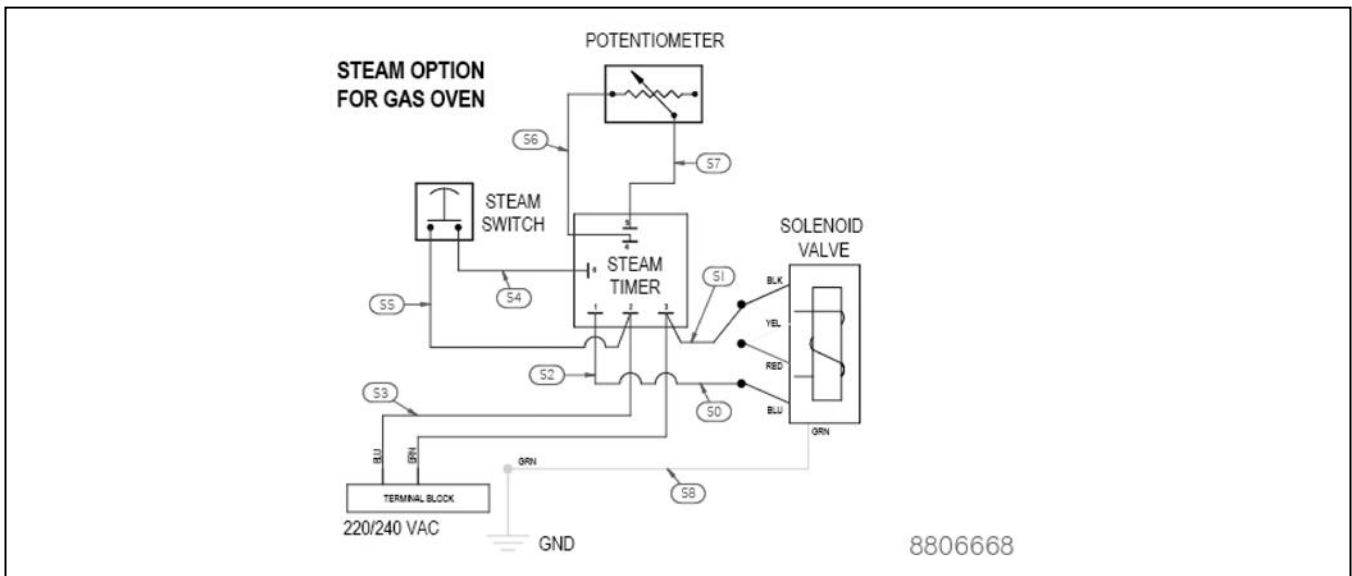

Wiring Diagram – Steam Injection 220V/240V 02/11/10 REV –



ELECTRIC CONVECTION OVEN OPERATION MANUAL

BAKERS PRIDE LIMITED WARRANTY

WHAT IS COVERED	<p>This warranty covers defects in material and workmanship under normal use, and applies only to the original purchaser providing that:</p> <ul style="list-style-type: none">• The equipment has not been accidentally or intentionally damaged, altered or misused;• The equipment is properly installed, adjusted, operated and maintained in accordance with National and local codes and in accordance with the installation instruction provided with the product;• The serial number rating plate affixed to the equipment has not been defaced or removed.
WHO IS COVERED	<p>This warranty is extended to the original purchaser and applies only to equipment purchased for use in the U.S.A.</p>
COVERAGE PERIOD	<p>Cyclone Convection Ovens: BCO Models: One (1) Year limited parts and labor; (1) Year limited door warranty. GDCO Models: Two (2) Year limited parts and labor; (2) Year limited door warranty. CO11 Models: Two (2) Year limited parts and labor; (5) Year limited door warranty. All Other Products: One (1) Year limited parts and labor. Warranty period begins the date of dealer invoice to customer or ninety (90) days after shipment date from Bakers Pride - whichever comes first.</p>
WARRANTY	<p>This warranty covers on-site labor, parts and reasonable travel time and travel expenses of the authorized service</p>
COVERAGE	<p>Representative up to (100) miles, round trip, and (2) hours travel time. The purchaser, however, shall be responsible for all expenses related to travel, including time, mileage and shipping expenses on smaller counter models that may be carried into a Factory Authorized Service Center, including the following models: PX-14, PX-16, P18, P22S, P24S, PD-4, PDC, WS Series and BK-18.</p>
EXCEPTIONS	<p>All removable parts in Bakers Pride® cooking equipment, including but not limited to: Burners, Grates, Radiants, Stones and Valves, are covered for a period of SIX MONTHS. All Ceramic Baking Decks are covered for a period of THREE MONTHS. The installation of these replacement decks is the responsibility of the purchaser. The extended Cyclone door warranty years 3 through 5 is a parts only warranty and does not include labor, travel, mileage or any other charges.</p>
EXCLUSIONS	<ul style="list-style-type: none">• Negligence or acts of God,• Failures caused by erratic voltages or gas supplies,• Thermostat calibrations after (30) days from equipment installation date,• Unauthorized repair by anyone other than a Bakers Pride Factory Authorized Service Center,• Air and Gas adjustments,• Damage in shipment,• Light bulbs,• Alteration, misuse or improper installation,• Glass doors and door adjustments,• Thermostats and safety valves with broken capillary tubes,• Fuses,• Char-broiler work decks and cutting boards,• Tightening of conveyor chains,• Adjustments to burner flames and cleaning of pilot burners,• Tightening of screws or fasteners,• Accessories — spatulas, forks, steak turners, grate lifters, oven brushes, scrapers, peels. etc.,• Freight — other than normal UPS charges,• Ordinary wear and tear.
INSTALLATION	<p>Leveling and installation of decks as well as proper installation and check out of all new equipment —per appropriate installation and use materials — is the responsibility of the dealer or installer, not the manufacturer.</p>
REPLACEMENT PARTS	<p>Bakers Pride genuine Factory OEM parts receive a (90) day materials warranty effective from the date of installation by a Bakers Pride Factory Authorized Service Center.</p>

This Warranty is in lieu of all other warranties, expressed or implied, and all other obligations or liabilities on the manufacturer's part. Bakers Pride shall in no event be liable for any special, indirect or consequential damages, or in any event for damages in excess of the purchase price of the unit. The repair or replacement of proven defective parts shall constitute a fulfillment of all obligations under the terms of this warranty.



1307 N. Watters Rd, Ste. 180 Allen, Texas 75013
Phone 800.527.2100 | Fax 914.576.0605 | bakerspride.com

Be sure to keep up with new product
announcements and events on social media!

