



SUPERDECK SERIES 6.75" DECK HEIGHT GAS PIZZA OVENS

SERIES: GS



Bakers Pride® GS series pizza ovens are designed for high-volume pizza and all-purpose baking operations. Each oven chamber features one Cordierite deck with 6.75" deck height and independently controlled top and bottom heat dampers for perfectly balanced results. These models come in two widths and constructed with heavy-duty, .25" angle iron frame, which is fully welded to allow for double-stacking. Oven exteriors are all heavy-duty, stainless steel and are fully insulated for cooler outer temperatures and consistent interior temperatures. Options are available to accommodate the configuration of your kitchen, such as side-mounted controls and custom-height legs.

FEATURES AT A GLANCE

- 60,000 total BTUH
- Natural or LP gas
- 300–650°F (148–343°C) temperature range
- 1.5" (38 mm) thick Cordierite decks
- Stackable
- 6.75" (171 mm) deck height
- Independently controlled top and bottom heat dampers
- Front- or side-mounted gas controls with valve, regulator, and pilot safety
- Heavy-duty, slide-out flame diverters
- All stainless steel exteriors, aluminized steel interiors
- Spring-balanced, fully insulated doors
- Left-side or rear 3/4" (19 mm) NPT gas connection
- Heavy-duty steel legs finished with durable Bakertone
- Fully insulated throughout
- Two-year limited warranty

OPTIONS & ACCESSORIES

- Stainless steel leg covers (per pair)
- Special-height legs (per set of four)
- 150–550°F (65–287°C) bake thermostat
- Draft flue for direct vent (not available on CE units)
- Automatic oven starter (comes with 120v plug)
- Deck brush and scraper (48" (1219 mm) long with wood handle)
- Stainless steel wood chip box
- Legs with casters
- Lightstone decks or steel decks



SUPERDECK SERIES 6.75" DECK HEIGHT GAS PIZZA OVENS

SERIES: GS

EQUIPMENT DIMENSIONS

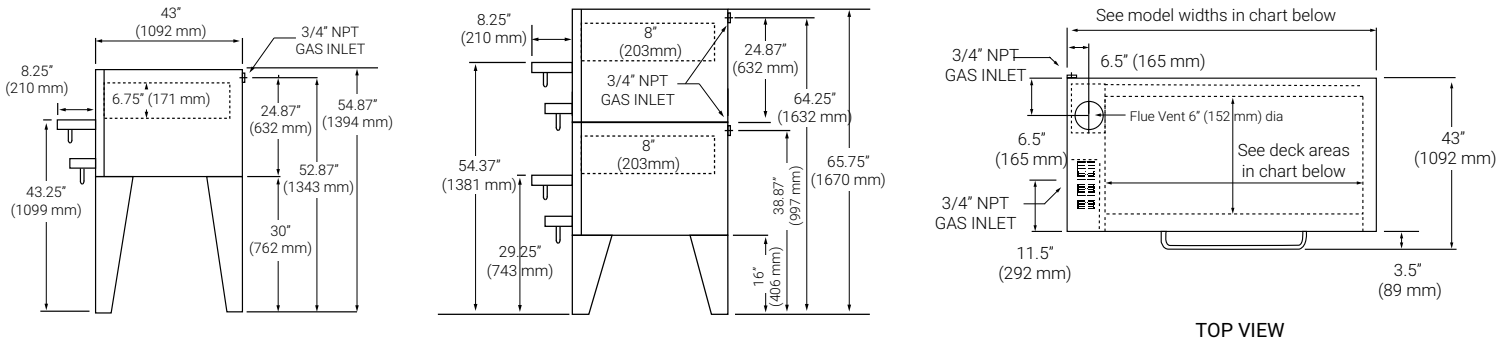

MECHANICAL SPECIFICATIONS

Model #	Overall Dim** (W x H x D)	Total BTUH***	kW***	Deck Height	Deck Size	Decks	Baking Chambers	Thermostat Range	Carton Dim (W x H x D)	Cubic Feet	Cubic Meter	Ship Wt. •
GS-805	53.25" x 54.87" x 43" (1353 x 1394 x 1092)	60,000	17.6	6.75" (171)	36" x 36" (914 x 914)	1	1	300°-650°F (148-343°C)	31" x 82" x 53" (787 x 2083 x 1346)	76	2.4	905 (411kg)
GS-990	53.25" x 65.75" x 43" (1353 x 1670 x 1092)	120,000	35.2	6.75" (171)	36" x 36" (914 x 914)	2	2	300°-650°F (148-343°C)	31" x 86" x 60" (787 x 2184 x 1524)	78	2.8	1073 (487kg)

•Each oven ships in separate carton as do the legs. Shipping weight shown includes all decks and legs.
 ••Height includes 30" (762 mm) legs on single units and 16" (406 mm) on stacked units. Height excludes dome accent.
 ***CE certification not available in LP gas

GAS CONNECTIONS

3/4"
 CE certification not available with LP gas
 Each deck requires a separate gas connection

REQUIRED CLEARANCES

	Non-Combustible Construction	Combustible Construction
Left	0" (0 mm)	1" (25 mm)
Right	0" (0 mm)	3" (76 mm)
Back	2" (51 mm)	3" (76 mm)

Bakers Pride reserves the right to modify specifications or discontinue models without incurring obligation. Dimensions nominal.



Freight Class: 77.5
 FOB Allen 75013

10.11.2019

