



## RESTAURANT SERIES RANGES

### SERIES: BP-48"



Bakers Pride® 48" ranges feature two 30,000 BTUH ovens. Choose from variety of stovetop configurations: an eight-burner range, a single 48" griddle, or two, four, or six burners combined with a 12", 24", or 36" griddle.

Cleaning is easy thanks to the lift-off burner heads and removable oven doors. The cast-iron section grates are designed to allow pots to slide from section to section and are engineered with an anti-clogging shield for long-lasting performance. In the oven, a unique burner baffle distributes heat evenly throughout the oven, which is also porcelainized on five contact surfaces.

For even more control within the cooking chamber, choose the optional convection oven. Simply turn the motor off to use it as a standard oven.

Available for use with natural gas or liquid propane.

#### VANTAGE STOVETOP CONFIGURATION

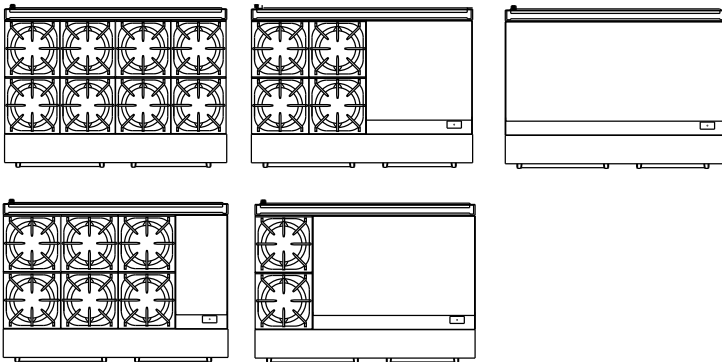

#### FEATURES AT A GLANCE

- 40,000 BTUH burners
- Lift-off burner heads
- Natural gas or LP gas
- Two 20" (508 mm) wide, 30,000 BTUH ovens
- 1" (25 mm) thick griddle (on specific models)
- Burner for every 12" (305 mm) of griddle surface
- 12" (305) sq. cast-iron section grates
- 7" (178 mm) landing ledge
- 6" (152 mm) adjustable legs
- Oven is porcelainized on bottom, sides, back, and door liner
- Rack guides have four positions for two standard wire racks (Ribbed bottom is fifth position.)
- Unique burner baffle design
- Removable oven doors
- Stainless steel front, sides, landing ledge, back guard, and shelf
- Anti-clogging grate shield
- One-year limited warranty

#### OPTIONS & ACCESSORIES

- Convection ovens
- Left-hand griddle (Right is standard.)
- Raised griddle
- Additional oven racks
- Quick disconnect and flexible gas hose
- Casters (set of six)
- Gas conversion kits
- Thermostatic griddle
- Stub back



# RESTAURANT SERIES RANGES

## SERIES: BP-48"

### EQUIPMENT DIMENSIONS

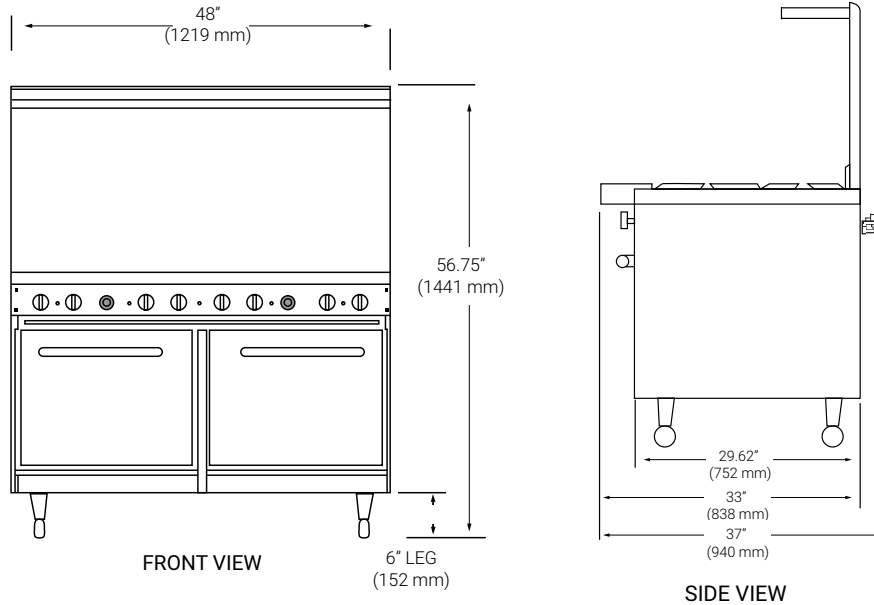

### MECHANICAL SPECIFICATIONS

Model #	BTU	# 12" sq. Grates	Griddle Width	Oven Width	Overall Dim (W x H x D)	Carton Dim (W x H x D)	Cubic Feet	Cubic Meter	Ship Wt.
48-BP-8B-S20	380,000	8	n/a	20" (508)	48" x 56.75" x 37" (1219 x 1441 x 940)				740 (336kg)
48-BP-6B-G12-S20	320,000	6	12" (305)	20" (508)	48" x 56.75" x 37" (1219 x 1441 x 940)				775 (352kg)
48-BP-4B-G24-S20	260,000	4	24" (610)	20" (508)	48" x 56.75" x 37" (1219 x 1441 x 940)				825 (374kg)
48-BP-2B-G36-S20	200,000	2	36" (914)	20" (508)	48" x 56.75" x 37" (1219 x 1441 x 940)				865 (392kg)
48-BP-0B-G48-S20	140,000	n/a	48" (1219)	20" (508)	48" x 56.75" x 37" (1219 x 1441 x 940)				885 (401kg)

\*Height includes 6" legs. Depth includes 4" gas regulator.

### OVEN INTERIOR DIMENSIONS

20.5" x 15" x 26.5"  
(521 x 381 x 673)

### REQUIRED CLEARANCES

Combustible  
 Left 10" (254 mm)  
 Right 10" (254 mm)  
 Back 4" (102 mm)

### GAS CONNECTIONS

Manifold pressure is 5.0" W.C. or natural gas o 10.0" for propane gas. Manifold size is 3/4" NPT.  
 3/4" pressure regulator supplied with equipment to be installed at time of connection.  
 Must specify type of gas and elevation if over 2000 ft. when ordering.



Freight Class: 110  
 FOB: Allen, 75013

Bakers Pride reserves the right to modify specifications or discontinue models without incurring obligation. Dimensions nominal.

Bakers Pride Oven Company, LLC is a wholly owned subsidiary of Standex International Corporation.

11.13.2017

