

Blueair by  
BLUENIX

# MODEL BAPP93-D6-HC PIZZA PREP TABLES



## Stainless steel cabinet construction

Stainless steel interior and exterior (galvanized steel back & bottom).



## Temperature range between 33°F ~ 39°F

Air guard on rear wall ensures proper air circulation and cooling.



## Hydrocarbon refrigerants (R-290)

Increases energy HFC refrigerants. It is safer for the environment and does not cause ozone depletion.



## Cabinet Dimensions (inches/mm)

L	D	H
93 1/4" 2370 mm	36 1/2" 929 mm	42" 1066 mm

## Weight (lbs/kg)

Net Weight 518 lbs 234 kg	Ship Weight 558 lbs 253 kg
---------------------------------	----------------------------------



Conforms to NSF/ANSI 7(ETL)



## Cabinet construction

- Cyclopentane Insulation – Contains no hydro-fluorocarbons (HFCs) and is environmentally friendly.
- Epoxy coated wire shelves with adjustable shelving height.
- Drop-in section : Fans force cold air into this enclosed area keeping stored food items consistently cold
- Insulated pan cover with a stainless steel divider which prevents food spillage into the storage area beneath
- Standard 1/6 / 4" food pans are provided. Unit accommodates 6" deep pans
- Side rail cutting board bracket with 9 1/2" deep, 1/2" thick cutting board included
- Four 4" Diameter swivel casters with front brakes standard.

## Refrigeration

- Self-contained system, rear mounted compressor.
- Electrodeposition coated evaporator increases performance by maintaining the heat transfer rates over the life of the evaporator and reducing potential corrosion.
- Innovative hot gas frame heating system reduces condensation and increases energy.

Front view

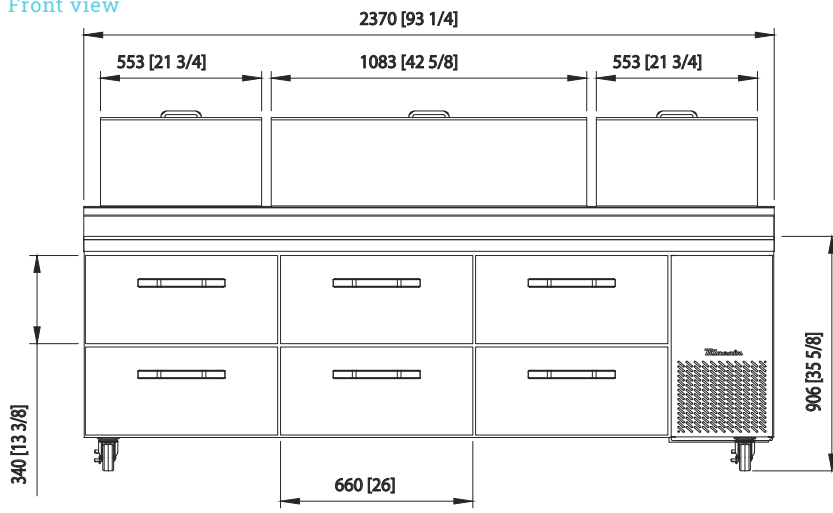

Side view

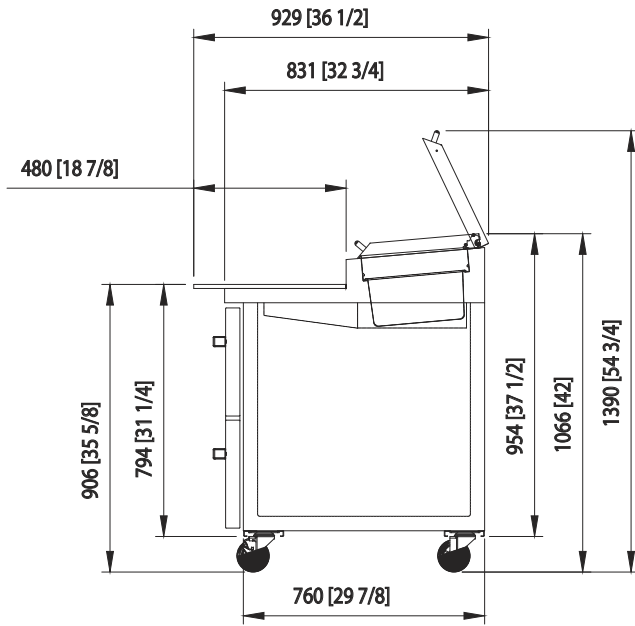

Top view

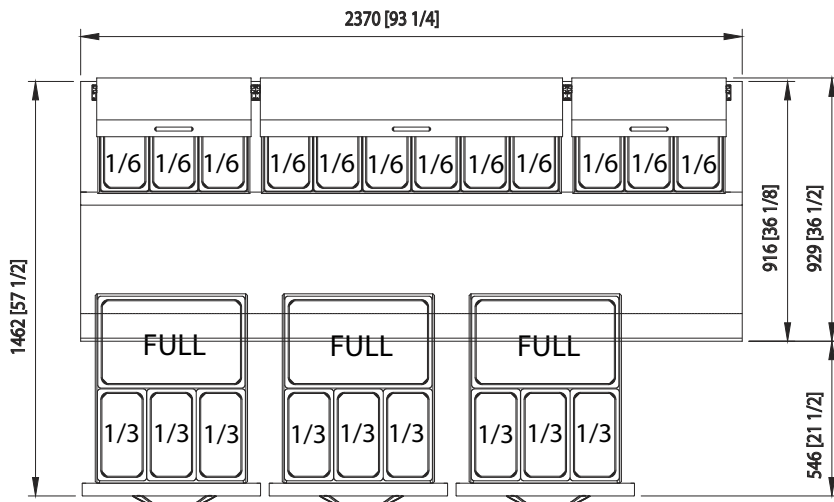

## Doors

- Self-closing doors
- Durable door gasket with easy replacement.
- Lifetime guaranteed heavy duty all metal door handles. (Ni-Cr Plated)
- Door designed to open easily.

## Design & Features

- Self-diagnostic digital temperature control & monitor system.
- Digital display allows for easy monitoring.
- Digital controls include automatic evaporator fan motor delay
- Rounded corner design gives a stylish appearance and reduces chances of injury.
- Visual and audible door open alarm, alarm sounds when doors are not completely closed to protect against food spoilage

## Optional Features & Accessories

- 2.5" diameter casters available.
- 6" adjustable legs available.
- Additional shelves are available.
- 6" pans available

Door	N/A
Drawer	6
Capacity Cu.Ft.	30.8
Shelves	N/A
Refrigerant	R-290
Temperature Range	33°F ~ 39°F
Easy Maintenance	Sliding Condensing Unit
Connection	9.8 ft long (3m) flexible three wire cord with modeled plug
HP	3/8
Voltage	115V/60Hz
Amps	3.5
NEMA Config.	NEMA 5-15



- This product may expose you to chemicals including Diisononyl Phthalate(DINP), which is known to the State of California to cause cancer. For more information go to [www.P65Warnings.ca.gov](http://www.P65Warnings.ca.gov).  
- Ce produit peut vous exposer à des agents chimiques incluant le Diisononyl Phthalate(DINP), reconnu par l'Etat de Californie comme causant le cancer. Pour de plus amples renseignements, consulter le site [www.P65Warnings.ca.gov](http://www.P65Warnings.ca.gov).

**Blueair by**  
**BLUENIX**

Blue Air has right to change specifications without further notice.



[blueairfse.com](http://blueairfse.com)



[orders@blueairfse.com](mailto:orders@blueairfse.com)



1-886-677-8500



223 W. Rosecrans Ave., CA 90248  
T: 310-808-0102

9 W. Shelton Terrace #A, Hillside, NJ 07205  
T: 908-688-0970