



SALAD / SANDWICH PREP TABLES

Features

- CFC free refrigerant and foam insulation
- Electronic thermostat and digital LED temperature display for accurate control and easy reading
- Easy to mount 2.5" casters (two lockable in front) are standard with all units
- Self-closing doors that remain open at 90 degrees
- Magnetic gasket can be replaced without any tools
- Adjustable, heavy-duty epoxy coated wire shelves (one per door)
- Stainless steel framework construction
- Auto defrosting and auto evaporation of condensation water
- 1/6 x 4" Portion Control pans & 11.4" Polyethylene cutting board included
*Unit can be custom-ordered with 6" PC pans
- Exterior: 430 stainless steel top, front & sides. Aluminum back panel & galvanized bottom
- Interior: 304 stainless steel floor, ABS sides & door backs. Aluminum back panel
- R-290 Natural refrigerant
- Temperature: 33 to 40°F / 0.5 to 4°C
- Electrical: 115/60/1 with NEMA 5-15P plug, 10ft cord



NEMA
5-15P



ISP29



ISP48



ISP61



ISP72

Options - Drawers*

ISP29-2D | ISP48-2D | ISP48-4D | ISP61-2D | ISP61-4D

*Available by custom order only. Please contact our Sales Department for availability and lead time.

Specifications

DESIGNED TO OPERATE IN AMBIENT TEMPERATURES BETWEEN 40F-90F FOR OPTIMUM PERFORMANCE.



Certified to ANSI/NSF-7 Standards

Model	Doors	Ext. Dimensions W X D X H (In)	Int.. Dimensions W X D X H (In)	Amps	H.P	Ship Weight
ISP29	1	28.9 X 29.9 X 43.2	25.6 X 25.6 X 24.2	3	1/3	225 lbs
ISP48	2	48.2 X 29.9 X 43.2	43.5 X 25.6 X 24.2	4.3	1/2	322 lbs
ISP61	2	61.2 X 29.9 X 43.2	56.5 X 25.6 X 24.2	4.3	1/2	373 lbs
ISP72	3	71.7 X 29.9 X 43.2	67.0 X 25.6 X 24.2	4.3	1/2	408 lbs



SALAD / SANDWICH PREP TABLES



Certified to ANSI/NSF-7 Standards

Dimensions in inches (mm)

ISP29

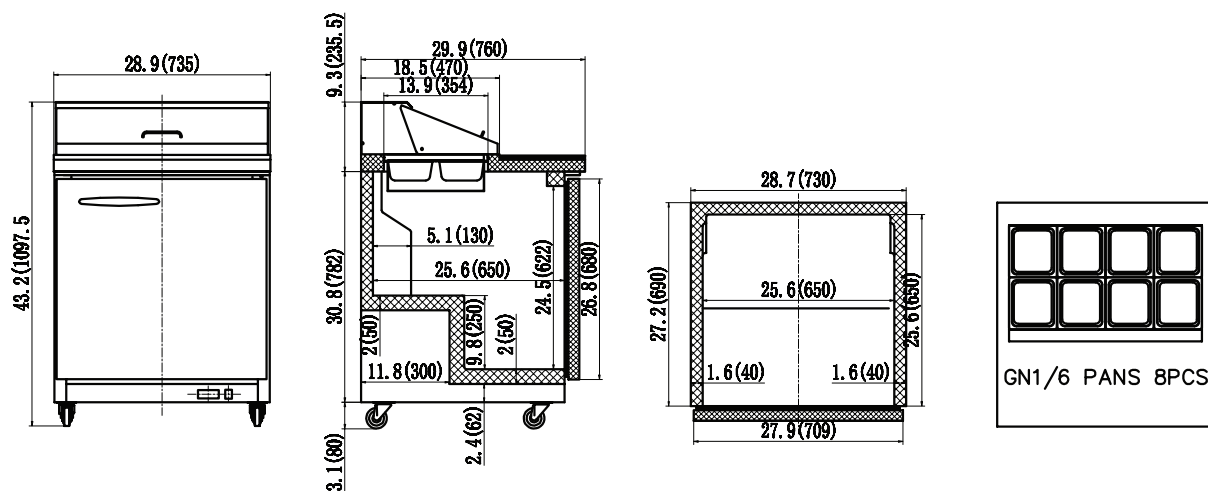

ISP48

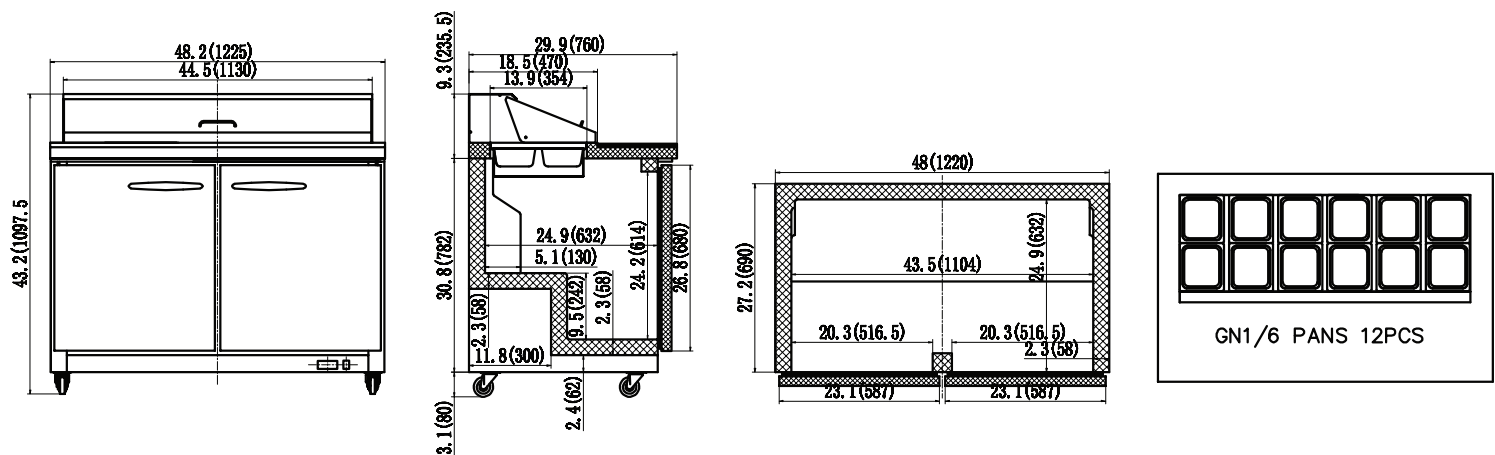

ISP61

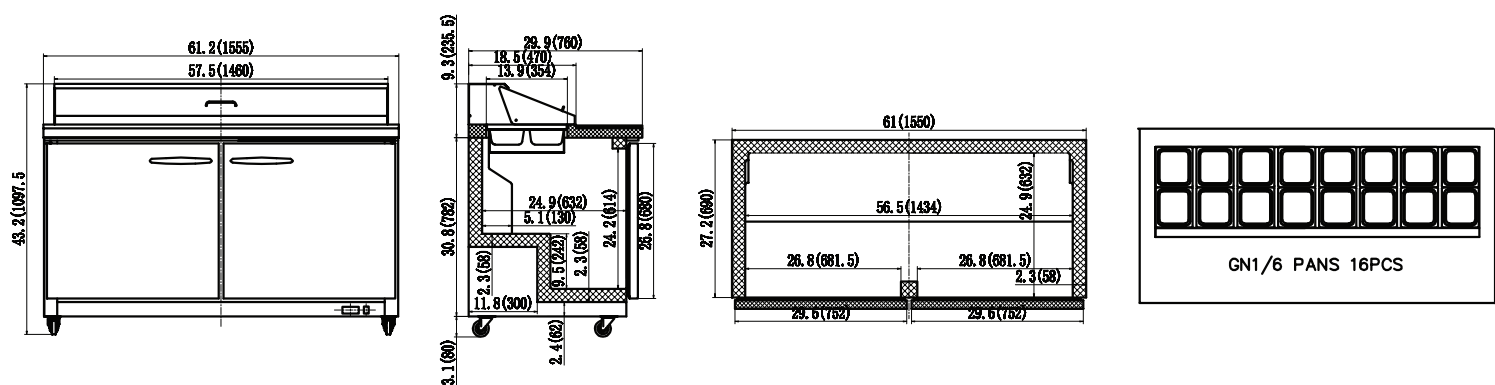

ISP72

