



# BACK BARS SWING DOORS

## Features

- CFC free refrigerant and foam insulation
- Electronic thermostat and digital LED temperature display for accurate control and easy reading
- Stainless steel framework construction
- Magnetic door gaskets can be replaced without any tools
- Doors have lock and key
- Adjustable, heavy-duty epoxy coated wire shelves (two per door)
- Easy to mount 4" casters (two lockable in front) are standard with all units
- Mono-block unit
- Top: 430 stainless steel
- Interior: 430 stainless steel with 304 stainless steel floor
- Exterior: Heavy duty, wear resistant black paint
- Temperature: 33 to 40°F / 0.5 to 4°C
- Electrical: 115/60/1 with NEMA 5-15P plug, 10ft cord
- R-290 Natural refrigerant
- IBB49-2G-24 holds: 48 x 6 pks of 12 oz. cans or 216 12 oz. bottles
- IBB61-2G-24 holds: 72 x 6 pks of 12 oz. cans or 324 12 oz. bottles
- IBB73-3G-24 holds: 84 x 6 pks of 12 oz. cans or 378 12 oz. bottles



IBB49-2G-24



IBB61-2G-24



IBB73-3G-24

## Specifications

DESIGNED TO OPERATE IN AMBIENT TEMPERATURES BETWEEN 40F-90F FOR OPTIMUM PERFORMANCE.



Certified to ANSI/NSF-7 Standards

Model	Doors	Ext. Dimensions W X D X H (In)	Int.. Dimensions W X D X H (In)	Amps	H.P	Ship Weight
IBB49-2G-24	2	49.1 X 24.4 X 41.7	36 X 20.01 X 29.37	3	0.40	307 lbs
IBB61-2G-24	2	61.1 X 24.4 X 41.7	48 X 20.01 X 29.37	3	0.40	358 lbs
IBB73-3G-24	3	73.1 X 24.4 X 41.7	60 X 20.01 X 29.37	3	0.43	417 lbs

# BACK BARS SWING DOORS



Certified to ANSI/NSF-7 Standards

Dimensions in inches (mm)

IBB49-2G-24

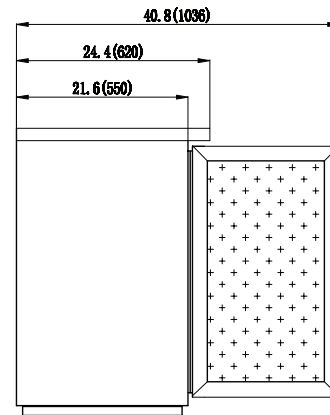
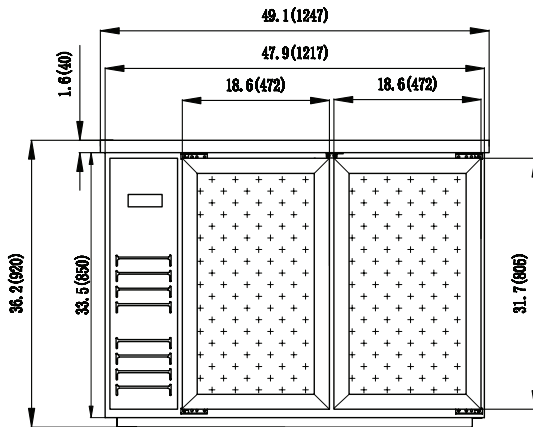

IBB61-2G-24

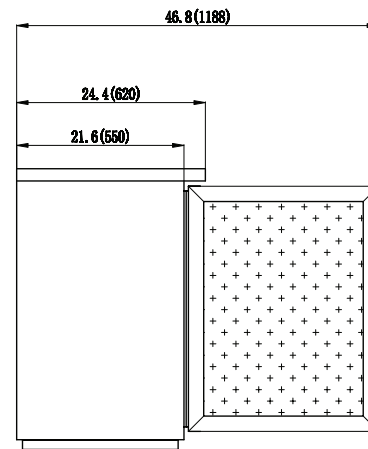
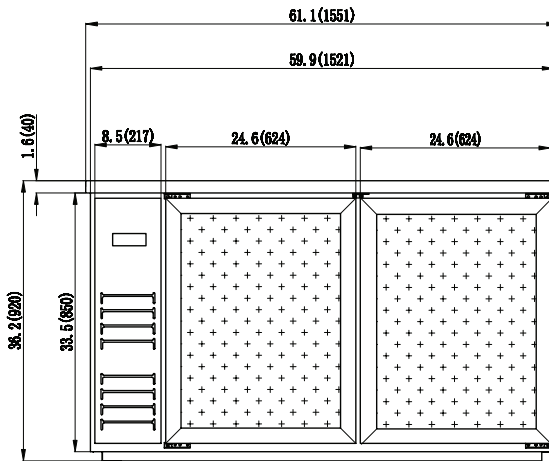

IBB73-3G-24

